

**HP 11807A,E Option 100 System Support Tests
User's Guide for the HP 8920A, HP 8920B,
HP 8921A**

Software Revision B.02.00 and above

Manual Part Number: 11807-90141

Manual Revision C

Printed in U.S.A.

August 1999



Notice

Information contained in this document is subject to change without notice.

All Rights Reserved. Reproduction, adaptation, or translation without prior written permission is prohibited, except as allowed under the copyright laws.

This material may be reproduced by or for the U.S. Government pursuant to the Copyright License under the clause at DFARS 52.227-7013 (APR 1988).

© Copyright 1997 Hewlett-Packard Company

Introduction

HP 11807A,E System Support Tests	8
Items Supplied in the Software Package	9
Equipment Needed	9
Firmware Revision Requirements	9
Hardware That Must be Installed in the Test Set	10
Additional Services Available	11

Loading and Running the Software

Testing Overview	15
Running Tests	16
Loading the Software	17
Starting Up	18
Customizing Testing	20
Beginning Software Customization	22
Changing the Order of Tests	23
How to Change the Order of Tests	24
Changing the Test Parameters	26
How to Change the Test Environment and Conditions	26
Saving a Test Procedure	28
How to Save a Test Procedure	29
Changing Test Execution Conditions	32
How to Change Test Execution Conditions	33
Printing and Saving Test Results	33

RFTOOLS Library: Procedure, Test, and Parameter Descriptions

Procedures Pre-programmed in the RFTOOLS Library	37
Test Descriptions	38
Swept Gain Test	38
Swept Insertion Loss Test	40
Swept Return Loss Test	42
AMPS Channel Return Loss Test	45
Cable Fault Test	47
ERP Calculator	53
Replot Data Files	54
Transfer Stored Data	56
SA Self Calibration ON/OFF	57
Catalog Memory Card	58
Create/Edit Data Collection Labels	59
RF Tools: Parameter Descriptions	61
Parm_01 Sweep Start Frequency [.4 to 1000 MHz]	61
Parm_02 Sweep Stop Frequency [.4 to 1000 MHz]	61
Parm_03 Gain: plot scale [1, 5, 10] (dB/div)	61
Parm_04 Gain: maximum expected gain [-50 to 20] (dB) ...	62

Contents

Parm_05 Gain: DUPLEX OUT level [-54 to +10] (dBm)	62
Parm_06 Inser. loss: maximum expected [-50 to 0]	62
Parm_07 Inser. loss: DUPLEX OUT level [-54 to +10]	62
Parm_08 Return loss: maximum expected [-50 to 0]	63
Parm_09 Return loss: DUPLEX OUT level [-54 to +10]	63
Parm_10 Discrete return loss: start chan [AMPS]	63
Parm_11 Discrete return loss: stop chan [AMPS]	63
Parm_12 Discrete return loss: channel step size	64
Parm_13 Discrete return loss: off freq [0 to 20]	64
Parm_14 Discrete return loss: band [0=FWD 1=REV]	64
Parm_15 Discrete return loss: DUPLEX OUT [-54 to +10] . .	64
Parm_16 Cable fault: cable length	64
Parm_17 Cable fault: length units [0=ft 1=m]	65
Parm_18 Cable fault: [0=RG 1=HELIAX 2=Custom]	65
Parm_19 Cable type: [1>13 for Heliac, # for RG]	66
Parm_20 Cable fault: custom cable attenuation (dB/unit) . .	66
Parm_21 Cable fault: custom cable prop. velocity (<1.0) . .	67
Parm_22 Use data collection labels [0=No 1=Yes]	67
Parm_23 Show all data files [0=No 1=Yes]	68
FIELD_S Library: Procedure, Test, and Parameter Descriptions	
Procedures Pre-programmed in the FIELD_S Library	70
Setting Up Test Frequencies for the FIELD_S Library	70
Test Descriptions	72
TEST_01 Measure Test Plan	72
TEST_02 Print Stored Measured Data	73
Field Strength Test: Parameter Descriptions	74
Parm_01 Antenna Gain	74
Parm_02 Number of times to average reading	74
INTRMOD Library: Procedure, Test, and Parameter Descriptions	
Procedures Pre-programmed in the INTRMOD Library	76
Test Descriptions	77
TEST_01 Calculate Intermods	77
Setting Up Intermodulation Products Parameters	77
SCANNER Library: Procedure, Test, and Parameter Descriptions	
Procedures Pre-programmed in the SCANNER Library	80
Setting Up Discrete Scan Frequency Information	80
Setting Up Swept Scan Frequency Information	82
Test Descriptions	83
TEST_01 SCANNER	83
Parameter Descriptions	84
Parm_01 Receiver dwell time (seconds)	84
Parm_02 Wide IF bandwidth [0=no 1=yes]	84

Save/Recall Register Utility (SAVRCL)

Catalog the Memory Card	87
Purge Files from the Memory Card	88
Saving Registers to a Memory Card	89
Restoring (Copying) Registers to the Test Set	91
Formatting a Memory Card	92

Reference (Alphabetical)

Conventions Used	95
Copying Files	96
Data Collection (Saving and Retrieving Test Results)	97
Collection to a Memory Card	97
Retrieving Data from a Memory Card	100
Collection to a PC	100
Configuration for Terminal or PC Operation	103
HP-IB Control Annunciators	109
Memory Cards	110
SRAM Memory Cards	111
Memory Card Storage Space	112
Initializing an SRAM Memory Card	113
Retrieving Data from a Memory Card	114
Parameters	115
Pass/Fail Limits (specifications)	116
Pausing or Stopping a TEST	117
Printing	118
Supported Printers	118
Printer Connection	119
Configuring the Test Set for Printing	120
To Setup a Printer	121
Procedures	125
Saving a Procedure	126
Loading a Procedure	128
Deleting a Procedure	128
Securing a Procedure	129
RAM	131
Initializing RAM Disks	132
Saving Tests Results	134
Test Execution Conditions	135
Output Results To: (Output Destination)	135
Output Results For: (Output Results)	135
Output Heading	136
If Unit-Under-Test Fails (If UUT Fails)	136
Test Procedure Run Mode (Run Mode)	136

Contents

Autostart Test Procedure on Power-Up	136
USER Keys	137
Appendix A: RFTOOLS Program Tutorial	139
Running the RFTOOLS Tests	141
Customize the Parameters	142
Running the Swept Return Loss Test	148
Running the Replot Data Files Test	156
Plotting Two Files	158
Overview of the Cable Fault Test	161
Selecting Cable Class: RG	162
Running the Cable Fault Test	165
Glossary	175

1 Introduction

HP 11807A,E System Support Tests

The HP 11807A,E Option 100 System Support Tests software is stored on a one-time programmable (OTP) memory card. The test set's built-in computer (operating with HP Instrument BASIC programming language) allows you to run the following individual programs:

- [“RFTOOLS Library: Procedure, Test, and Parameter Descriptions” on page 35](#)
 - Swept Gain
 - Swept Insertion Loss
 - Swept Return Loss
 - AMPS Channel Return Loss
 - Cable Fault
 - ERP Calculator
 - Replot Data Files
 - Transfer Stored Data
 - SA Self Calibration ON/OFF
 - Catalog Memory Card
 - Create/Edit Data Collection Labels
- [“FIELD_S Library: Procedure, Test, and Parameter Descriptions” on page 69](#)
 - Performs Field Strength Measurements
- [“INTRMOD Library: Procedure, Test, and Parameter Descriptions” on page 75](#)
 - Calculates Intermodulation Products
- [“SCANNER Library: Procedure, Test, and Parameter Descriptions” on page 79](#)
 - Discrete Frequency Scanning
 - Swept Frequency Scanning
- [“Save/Recall Register Utility \(SAVRCL\)” on page 85](#)
 - Catalog Memory Card
 - Purge Files From a Memory Card
 - Copy Save/Recall Registers From a Test Set to a Memory Card
 - Copy Save/Recall Registers from a Memory Card to a Test Set
 - Format a Memory Card

Items Supplied in the Software Package

The HP 11807A,E Option 100 Software Package contains the following items:

- HP 11807A,E Option 100 Software User's Guide (HP part number 11807-90141)
- HP 11807A Option 100 Software Card (HP part number 11807-10100) or
- HP 11807E Option 100 Software Card (HP part number 118007-10032)
- HP software product license agreement

Equipment Needed

To run the Option 100 System Support Tests, the following hardware must be configured in the test set or available externally:

Firmware Revision Requirements

All HP 8920B Test Sets can use this software package.

HP 8920A and HP 8921A Test Sets should have firmware revision A.14.00 or higher to run this software. Although the software may run successfully on earlier revisions, operation is slightly different and may not be reliable.

The firmware revision number is displayed at the top of the screen when the Test Set is turned on, and remains displayed until a button is pressed or the knob is turned. You can also verify the revision by pressing the **SHIFT, DUPLEX (CONFIG)** keys to access the CONFIGURE screen; the revision number is displayed in the upper-right corner of that screen.

If your HP 8920A/21A Test Set has an earlier firmware revision (before A.14.00), contact your local HP sales representative about getting a firmware update.

Hardware That Must be Installed in the Test Set

- Option 102, spectrum analyzer and tracking generator (for the gain, swept insertion loss, swept return loss, discrete return loss, and cable fault tests).

NOTE

The item listed above is available as an option for the HP 8920A,B. It is standard in the HP 8921A

Table 1-1 External Hardware for the System Support Tests

Test Procedure	Hardware Required	Quantity	Part Number
Cable Fault (C_Fault)	Resistive Power Splitter 1 GHz, BNC(f), 3 dB	1	Eagle HPS101 ¹
	50 Ω Termination connector type as required	1	None
Swept Gain and Swept Insertion Loss	6 dB Pad, BNC(f) to BNC(m)	2	HP 0955-0698
	BNC(m) to BNC(m) Cable, 1 ft	2	HP 08120-1838 ²
	BNC (f) to BNC(f) Adapter	1	HP 1250-0780
Swept Return Loss and Discrete Return Loss	SWR Bridge	1	Eagle RLB150N3B or equivalent
Frequency Scanning	Antenna with BNC connector	1	None
Field-Strength Measurement	Intialized SRAM Memory Card	1	(for HP 11807A,E), HP 85700A
	Antenna with BNC (m) connector	1	None
For PC to Serial Port Input	DB9(f) to RJ11(m) cable	1	HP 08921-60038

1. Eagle, P.O. Box 4010, Sedona, AZ 86340, (Tel: 520-204-2597) (Fax: 520-204-2568)

2. Alternate part to substitute for these two components in an N(m) to BNC(m) cable, Eagle part number CCS050-BN-C2.0

NOTE

A kit containing all components necessary for performing these tests is available from Eagle using part number: BKH-8920.

Additional Services Available

Consult the test set Reference Guide or call the HP 8920 Hotline 1-800-922-8920 (USA and Canada only) and give your software model number if you encounter a problem.

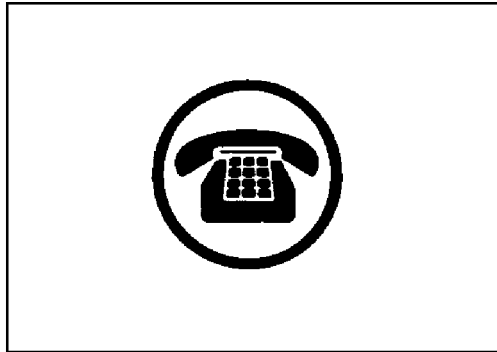
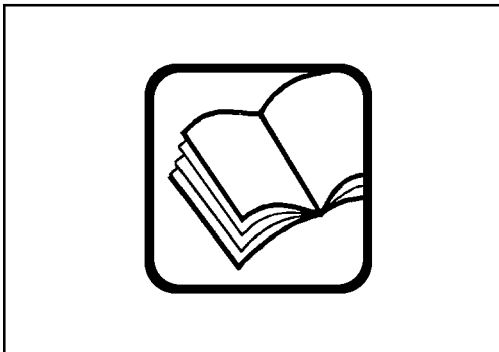

2 Loading and Running the Software

The software can be run on the factory default settings or customized to your individual needs and specific requirements. This chapter provides detailed information on how to load, run, and customize the software.

The test set has two methods of accessing on-line help. In each of the screens in the test environment, **k4 (Help)** accesses specific information about how to set up/use the current screen. Pressing **SHIFT, TX(HELP)** accesses the test set's complete help file, with an alphabetical listing of help topics.

Testing Overview

Pressing **TESTS** displays the TESTS (Main Menu) screen. To begin testing, you must first select a procedure filename. From the **Main Menu** you have the option to:

Begin running tests:

- The factory default settings are acceptable for your application or
- The software has already been customized and saved to a memory card

Customize the software:

- Decide which tests you desire to run (Order of Tests)
 - you may want to run all, some, or just one of the tests.
- Change the test environment and conditions (Test Parameters)
 - decide output format.
 - enter specific information about radio equipment and/or environment.
- Save any or all of the above customized changes to a memory card (Save/Delete Procedure)

Set Up Test Set:

- Print test results or certain screens.
- Decide when and where test results are displayed (**Test Execution Conditions/External Devices**)

Running Tests

The HP 11807A,E Software can be run with its factory default settings, or it may be customized to your specific needs (see “[Customizing Testing](#)” on page 20).

When tests are run, they are executed in the order in which they were entered into the Test Procedure.

- When displayed, pressing **CANCEL** will pause the current test (press **k2** (**Continue**) to continue the test).

Loading the Software

Before you begin testing, you must load the software into the test set memory. To load the software, you must first select the location to load from (in this case, it will be **Card**) and a procedure filename. The HP 11807A,E Option 100 card comes pre-programmed with five procedures, and four different libraries. Each library is associated with its own software program. The actual software program does not get loaded into the test set memory until **k1 (Run Test)** is selected. It will take approximately two minutes for the software program to be loaded at that time.

The software memory card can be removed after the program is loaded into the test set memory. The program will remain in memory after a power-down/power-up cycle, unless it is manually deleted or a new program is loaded (for example, if you select a procedure in a different library).

Starting Up





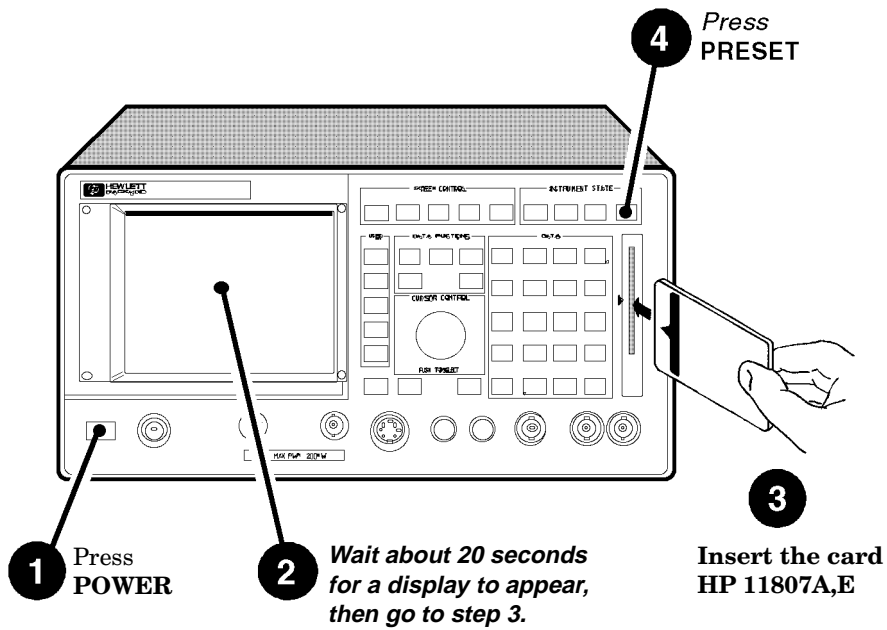





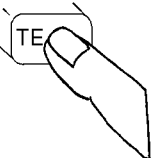

**Do steps 1-4 in
numbered order.**

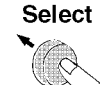
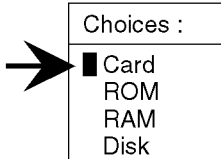
*(PRESET is a reset command that
can be used at any time to restart.)*

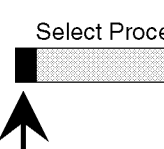

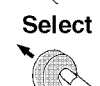
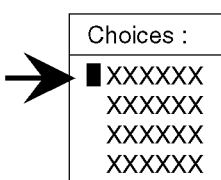
LOAD1b

Continue on next page

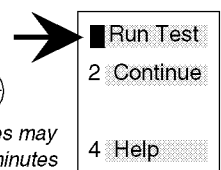
<p>5 Press TESTS to display the TESTS (Main Menu) screen.</p> <p><i>If you are in IBASIC, press SHIFT, CANCEL before pressing TESTS.</i></p> 	<p>6 Position cursor at Select Procedure Loc... and select it.</p> <p>Position </p> <p>Select </p> <p>Select Procedure Location: </p>
<p>7 Position cursor at Card and select it.</p> <p>Position </p> <p>Select </p> <p>Choices :  <ul style="list-style-type: none"> ■ Card ROM RAM Disk </p>	<p>8 Position cursor at Select Procedure File... and select it.</p> <p>Position </p> <p>Select </p> <p>Select Procedure Filename: </p>
<p>9 Position cursor at desired Procedure and select it.</p> <p>Position </p> <p>Select </p> <p>Choices :  <ul style="list-style-type: none"> ■ XXXXXX XXXXXX XXXXXX XXXXXX </p>	<p>10 Position cursor at RUN TEST and select it.</p> <p>Position </p> <p>Select </p> <p> Procedures may take 2-3 minutes to load.</p> <p> <ul style="list-style-type: none"> ■ Run Test 2 Continue 4 Help </p>

PRO1a

Customizing Testing

Because of the diversity of individual testing needs, the software has been designed so that changes may be easily made from the test set's front panel. You may store these changes on a memory card so that you may skip these steps in the future. See [“Saving a Test Procedure” on page 28](#).

Because your needs change, the software allows changes to its default settings whenever you need to make them. For example, tests may be inserted or deleted, and later after running the tests you can change the test parameters.

Most testing customization is accomplished through the customization screens. These customization screens are accessed from the main TESTS (Main Menu) screen as shown in the following figure. Customizing procedures is explained later in this chapter.

What is Not Explained in This Manual

Pass/Fail Limits, Channel Information, External Devices, Printer Setup, and IBASIC will not be explained in this customizing section.

- The Pass/Fail Limits settings are not used with the HP 11807A,E Option 100 Software.
- The Channel Information settings are used only in the FIELD_S and SCANNER libraries, each requiring different information. See the descriptions of these libraries in [Chapter 4](#) , “FIELD_S Library: Procedure, Test, and Parameter Descriptions,” on page 69 and [Chapter 5](#) , “INTRMOD Library: Procedure, Test, and Parameter Descriptions,” on page 75.
- The External Devices settings are used when setting up functions such as data collection. See “[Data Collection \(Saving and Retrieving Test Results\)](#)” on page 97.
- The Printer Setup settings are used to print the test results. See “[Printing](#)” on page 118.
- The IBASIC screen is used when writing your own programs and is not explained in this manual. If you need to write your own IBASIC programs you may acquire the following manuals:
 - *HP Instrument Basic User’s Handbook*
HP part number E2083-90000.
 - *HP Instrument Basic User’s Handbook (HP 8920B)*
HP part number E2083-90005.
 - *HP 8920A Programming Manual*
HP part number 08920-90220.
 - *HP 8921A Programming Manual*
HP part number 08921-90031
 - *HP 8920B Programming Manual*
HP part number 08920-90222

Beginning Software Customization

All software customization begins by accessing the TESTS (Main Menu) screen first and then selecting the **CUSTOMIZE TEST PROCEDURE** field of your choice. Press **TESTS** on the front panel of the test set to access the TESTS (Main Menu) screen.

Figure 2-1 TESTS (Main Menu) Screen

TESTS (Main Menu)	
RF TOOLS	1 Run Test
Revision: B.01.00	2 Continue
<u>LOAD TEST PROCEDURE:</u>	
Select Procedure Location:	4 Help
Card	
Select Procedure Filename: RFTOOLS	
Library: RFTOOLS	
Program: Card	
Description:	To Screen
Gain, Insertion Loss, Return Loss, Cable Fault	RF GEN
ERP Calculator, Data Transfer, and Plot Utilities	RF ANL
	AF ANL
	SCOPE
	SPEC ANL
	ENCODER
	DECODER
	RADIO INT
<u>CUSTOMIZE TEST PROCEDURE:</u>	More
<u>SET UP TEST SET:</u>	
Frea Channel Information	Exec Execution Cond
Parm Test Parameters	Cnfa External Devices
Sean Order of Tests	Print Printer Setup
Spec Pass/Fail Limits	IBASIC IBASIC Cntrl
Proc Save/Delete Procedure	

Changing the Order of Tests

You can define the order of tests to include all, some, or just one of the tests available. Each library has a different set of available tests. You cannot combine tests from different libraries into one procedure. When the first test is finished, the next will run. The test sequence will remain in the test set's battery backed-up memory until another test sequence is loaded or set up. For information on saving a customized test sequence, see [“Saving a Test Procedure” on page 28](#).











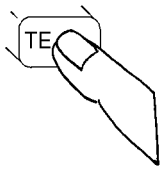







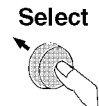

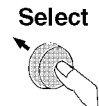

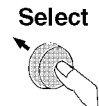
NOTE

Libraries are not selected directly. When you select a procedure filename, the associated library is automatically selected as well. The **Library** field on the TESTS (Main Menu) screen displays the current library. Note that each library has a separate set of tests and parameters. You may not combine tests from separate libraries into one procedure.

Defining the order of tests is accomplished by inserting or deleting tests from the list of tests in the active library. See “Test Descriptions” in [Chapter 4](#) through [chapter 6](#) describe the tests included in each library in this software package.

The following procedure describes how to create a new test sequence. The **All Chans** field is not used by this software package.



How to Change the Order of Tests

<p>1 Press TESTS to display the TESTS (Main Menu) screen.</p> <p>If you are in IBASIC, press SHIFT, CANCEL before pressing TESTS.</p> 	<p>2 Position cursor at Seqn Order of Tests and select it.</p> <table border="1"> <tr> <td data-bbox="714 409 860 661"> <p>Position</p>  <p>Select</p>  </td> <td data-bbox="860 409 1226 661"> <table border="1"> <tr><td>Freq</td><td>Channel Information</td></tr> <tr><td>Parm</td><td>Test Parameters</td></tr> <tr><td>Seqn</td><td>Order of Tests</td></tr> <tr><td>Spec</td><td>Pass Fail Limits</td></tr> <tr><td>Proc</td><td>Save/Delete Procedure</td></tr> </table> </td> </tr> </table>	<p>Position</p>  <p>Select</p> 	<table border="1"> <tr><td>Freq</td><td>Channel Information</td></tr> <tr><td>Parm</td><td>Test Parameters</td></tr> <tr><td>Seqn</td><td>Order of Tests</td></tr> <tr><td>Spec</td><td>Pass Fail Limits</td></tr> <tr><td>Proc</td><td>Save/Delete Procedure</td></tr> </table>	Freq	Channel Information	Parm	Test Parameters	Seqn	Order of Tests	Spec	Pass Fail Limits	Proc	Save/Delete Procedure
<p>Position</p>  <p>Select</p> 	<table border="1"> <tr><td>Freq</td><td>Channel Information</td></tr> <tr><td>Parm</td><td>Test Parameters</td></tr> <tr><td>Seqn</td><td>Order of Tests</td></tr> <tr><td>Spec</td><td>Pass Fail Limits</td></tr> <tr><td>Proc</td><td>Save/Delete Procedure</td></tr> </table>	Freq	Channel Information	Parm	Test Parameters	Seqn	Order of Tests	Spec	Pass Fail Limits	Proc	Save/Delete Procedure		
Freq	Channel Information												
Parm	Test Parameters												
Seqn	Order of Tests												
Spec	Pass Fail Limits												
Proc	Save/Delete Procedure												
<p>The Order of Tests screen is now present on your CRT.</p>	<p>3 Position cursor at Step # field and select it.</p> <table border="1"> <tr> <td data-bbox="714 766 860 1029"> <p>Position</p>  <p>Select</p>  </td> <td data-bbox="860 766 1226 1029"> <p>Example</p> <table border="1"> <tr> <td>"#"</td> <td>"TEST_#"</td> </tr> <tr> <td>"Test name"</td> <td></td> </tr> </table>  </td> </tr> </table>	<p>Position</p>  <p>Select</p> 	<p>Example</p> <table border="1"> <tr> <td>"#"</td> <td>"TEST_#"</td> </tr> <tr> <td>"Test name"</td> <td></td> </tr> </table> 	"#"	"TEST_#"	"Test name"							
<p>Position</p>  <p>Select</p> 	<p>Example</p> <table border="1"> <tr> <td>"#"</td> <td>"TEST_#"</td> </tr> <tr> <td>"Test name"</td> <td></td> </tr> </table> 	"#"	"TEST_#"	"Test name"									
"#"	"TEST_#"												
"Test name"													
<p>4 Rotate knob until Step # which precedes the insertion point of the new test you are adding is highlighted, then select it.</p> <table border="1"> <tr> <td data-bbox="214 1134 349 1390"> <p>Rotate</p>  <p>Select</p>  </td> <td data-bbox="349 1134 1226 1390"> <p>For example, select step 7 if you want to insert the new test as step 8.</p> <table border="1"> <tr> <td>"7"</td> <td>"TEST_#"</td> </tr> <tr> <td>"Test name"</td> <td></td> </tr> <tr> <td>"8"</td> <td>"New test"</td> </tr> </table>  </td> </tr> </table>		<p>Rotate</p>  <p>Select</p> 	<p>For example, select step 7 if you want to insert the new test as step 8.</p> <table border="1"> <tr> <td>"7"</td> <td>"TEST_#"</td> </tr> <tr> <td>"Test name"</td> <td></td> </tr> <tr> <td>"8"</td> <td>"New test"</td> </tr> </table> 	"7"	"TEST_#"	"Test name"		"8"	"New test"				
<p>Rotate</p>  <p>Select</p> 	<p>For example, select step 7 if you want to insert the new test as step 8.</p> <table border="1"> <tr> <td>"7"</td> <td>"TEST_#"</td> </tr> <tr> <td>"Test name"</td> <td></td> </tr> <tr> <td>"8"</td> <td>"New test"</td> </tr> </table> 	"7"	"TEST_#"	"Test name"		"8"	"New test"						
"7"	"TEST_#"												
"Test name"													
"8"	"New test"												



SEQ1a

Continue on next page



5 Position cursor at **Insrt Stp** and select it.

<p>Position</p>  <p>Select</p> 	 <ul style="list-style-type: none"> ■ Insrt Stp 2 Delet Stp 3 Print All 4 Help 5 Main Menu
---	--



6 Position cursor back at **Step #** field and select it.

<p>Position</p>  <p>Select</p> 	 <div style="display: flex; align-items: center; gap: 20px;"> <div style="border: 1px solid black; padding: 2px;">"7"</div> <div style="border: 1px solid black; padding: 2px;">"TEST #"</div> </div> <p>"Test name"</p>
---	--



7 Highlight **Step #** of the newly inserted test, then select it.

<p>Highlight</p>  <p>Select</p> 	<div style="display: flex; align-items: center; gap: 20px;"> <div style="border: 1px solid black; padding: 2px;">"8"</div> <div style="border: 1px solid black; padding: 2px;">"TEST #"</div> </div> <p>"Test name"</p> 
--	---

8 Position cursor at **Test Name** field, then select it.

<p>Position</p>  <p>Select</p> 	<div style="display: flex; align-items: center; gap: 20px;"> <div style="border: 1px solid black; padding: 2px;">"8"</div> <div style="border: 1px solid black; padding: 2px;">"TEST #"</div> </div> <p>"Test name"</p> 
---	---

9 Rotate knob until desired **Test Name** appears, then select it.

<p>Rotate</p>  <p>Select</p> 	<div style="display: flex; align-items: center; gap: 20px;"> <div style="border: 1px solid black; padding: 2px;">"8"</div> <div style="border: 1px solid black; padding: 2px;">"TEST #"</div> </div> <p>"Test name"</p> 
---	---

10 Press **TESTS** to return to the **TESTS (Main Menu)** screen

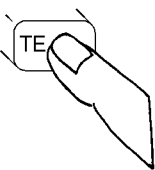

SEC2a

Changing the Test Parameters

The software uses parameters to optimize the test environment and conditions for your testing situation. Many of the test parameters are determined by examining your test needs. Each library has a unique set of parameters. Each procedure comes with default settings for test parameters. Review the defaults for your particular needs.







NOTE

The HP 11807A,E Option 100 software comes preprogrammed with four libraries: RFTOOLS, FIELD_S, INTRMOD, and SCANNER. The test, parameter, and channel information tables are different for each of these libraries. Each library accesses a separate software program, also contained on the software card. Each library will be described in its own chapter ([chapters 3 through 6](#))

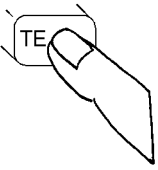
For information on saving customized test parameters, see [“Saving a Test Procedure” on page 28](#).

The following describes how you can change test parameter values through the Test Parameter screen to optimize your testing conditions.

How to Change the Test Environment and Conditions



<p>1 Press TESTS to display the TESTS (Main Menu) screen.</p>	<p>2 Position cursor at Parm Test Parameters and select it.</p>												
<p>If you are in IBASIC, press SHIFT, CANCEL before pressing TESTS.</p> 	<table border="1"><tr><td data-bbox="716 1129 868 1186">Position</td><td data-bbox="868 1129 1224 1186"></td></tr><tr><td data-bbox="716 1186 868 1260"></td><td data-bbox="868 1186 1224 1260">Freq Channel Information</td></tr><tr><td data-bbox="716 1260 868 1333">Select</td><td data-bbox="868 1260 1224 1333">Parm Test Parameters</td></tr><tr><td data-bbox="716 1333 868 1379"></td><td data-bbox="868 1333 1224 1379">Seqn Order of Tests</td></tr><tr><td></td><td data-bbox="868 1379 1224 1428">Spec Pass Fail Limits</td></tr><tr><td></td><td data-bbox="868 1428 1224 1480">Proc Save/Delete Procedure</td></tr></table>	Position			Freq Channel Information	Select	Parm Test Parameters		Seqn Order of Tests		Spec Pass Fail Limits		Proc Save/Delete Procedure
Position													
	Freq Channel Information												
Select	Parm Test Parameters												
	Seqn Order of Tests												
	Spec Pass Fail Limits												
	Proc Save/Delete Procedure												

PARM1a



Continue on next page

The Tests Parameters screen is now present on your CRT.

3 Position cursor at **Parm #** field and select it.



Position

Select

(Entries on your display may be different)



 1 RT audio test to
 0.00000





4 Scroll to **Parm #** to be changed and select it.



Scroll

Select

(This parameter number and description are examples)



 15 TX cable loss





5 Position cursor at **Value** field and select it.

Position

Select

 15 TX cable loss
 0.000000

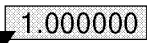
6 Use **DATA** keys to enter new value, then select it.

Enter

Select

 15 TX cable loss
 1.000000

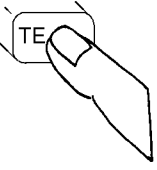
7 Press **TESTS** to return to the TESTS (Main Menu) screen.



PARM2a











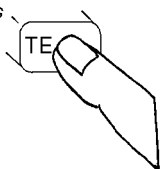
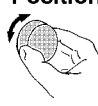

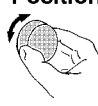

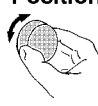





Saving a Test Procedure

A Test Procedure is a collection of test parameters and testing order (and channel information for FIELD_S and SCANNER libraries), saved in a file that customizes the test software to a specific application. You may save the file to a memory card or disk.

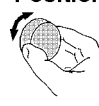
When you save a procedure you will be saving test parameters and testing order (and channel information in FIELD_S and SCANNER programs), plus a library containing the names of all test parameters and tests that are resident in the current library. The HP 11807A,E Option 100 software contains four libraries: RFTOOLS, FIELD_S, INTRMOD, and SCANNER. Each library file comes from the software and cannot be modified by the user. The current library file will be automatically saved on the card that is being used to store the new test procedure.

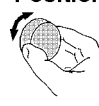
The following example shows how to save a new procedure to a memory card. For more information concerning procedures, see [“Procedures” on page 125](#).

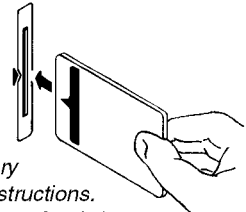
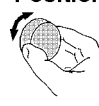



How to Save a Test Procedure

<p>1 Press TESTS to display the TESTS (Main Menu) screen.</p> <p>If you are in IBASIC, press SHIFT, CANCEL before pressing TESTS.</p> 	<p>2 Position cursor at Proc Save/Delete Pro... and select it.</p> <table border="1"> <tr> <td>Position</td> <td></td> <td> <table border="1"> <tr><td>Freq</td><td>Channel Information</td></tr> <tr><td>Parm</td><td>Test Parameters</td></tr> <tr><td>Seqn</td><td>Order of Tests</td></tr> <tr><td>Spec</td><td>Pass Fail Limits</td></tr> <tr><td>Proc</td><td>Save/Delete Procedure</td></tr> </table> </td> </tr> <tr> <td>Select</td> <td></td> <td></td> </tr> </table>	Position		<table border="1"> <tr><td>Freq</td><td>Channel Information</td></tr> <tr><td>Parm</td><td>Test Parameters</td></tr> <tr><td>Seqn</td><td>Order of Tests</td></tr> <tr><td>Spec</td><td>Pass Fail Limits</td></tr> <tr><td>Proc</td><td>Save/Delete Procedure</td></tr> </table>	Freq	Channel Information	Parm	Test Parameters	Seqn	Order of Tests	Spec	Pass Fail Limits	Proc	Save/Delete Procedure	Select		
Position		<table border="1"> <tr><td>Freq</td><td>Channel Information</td></tr> <tr><td>Parm</td><td>Test Parameters</td></tr> <tr><td>Seqn</td><td>Order of Tests</td></tr> <tr><td>Spec</td><td>Pass Fail Limits</td></tr> <tr><td>Proc</td><td>Save/Delete Procedure</td></tr> </table>	Freq	Channel Information	Parm	Test Parameters	Seqn	Order of Tests	Spec	Pass Fail Limits	Proc	Save/Delete Procedure					
Freq	Channel Information																
Parm	Test Parameters																
Seqn	Order of Tests																
Spec	Pass Fail Limits																
Proc	Save/Delete Procedure																
Select																	
<p>The Save/Delete Procedure screen is now present on your CRT.</p>	<p>3 Position cursor at Select Procedure Loc... and select it.</p> <table border="1"> <tr> <td>Position</td> <td></td> <td>Select Procedure Location:</td> </tr> <tr> <td>Select</td> <td></td> <td></td> </tr> </table>	Position		Select Procedure Location:	Select												
Position		Select Procedure Location:															
Select																	
<p>4 Position cursor at Card and select it.</p> <table border="1"> <tr> <td>Position</td> <td></td> <td> <table border="1"> <tr><td>Choices :</td></tr> <tr><td>Card</td></tr> <tr><td>RAM</td></tr> <tr><td>Disk</td></tr> </table> </td> </tr> <tr> <td>Select</td> <td></td> <td>(You can also save procedures to an internal RAM disk or external disk drive. See chapter 5-Disks.)</td> </tr> </table>	Position		<table border="1"> <tr><td>Choices :</td></tr> <tr><td>Card</td></tr> <tr><td>RAM</td></tr> <tr><td>Disk</td></tr> </table>	Choices :	Card	RAM	Disk	Select		(You can also save procedures to an internal RAM disk or external disk drive. See chapter 5-Disks.)	<p>5 Insert an initialized SRAM memory card.</p>  <p>(For detailed memory card initialization instructions, see chapter 5-Memory Cards.)</p>						
Position		<table border="1"> <tr><td>Choices :</td></tr> <tr><td>Card</td></tr> <tr><td>RAM</td></tr> <tr><td>Disk</td></tr> </table>	Choices :	Card	RAM	Disk											
Choices :																	
Card																	
RAM																	
Disk																	
Select		(You can also save procedures to an internal RAM disk or external disk drive. See chapter 5-Disks.)															





PROCMA1a

Continue on next page





6 Position cursor at **Enter Procedure File...** and select it.

Position

 Enter Procedure Filename:

Select







7 Select characters to name the procedure, then select **Done**.

Position

Select



 Choices :
 Done
 Position
 Over/Ins
 Delete
 Del End
 Bk space
 A
 B
 C





8 Position cursor at **Enter Description for ...** and select it.

Position

 Enter Description for r

Select





9 Select characters for the description, then select **Done**.

Position

Select



 Choices :
 Done
 Position
 Over/Ins
 Delete
 Del End
 Bk space
 A
 B
 C

10 Position cursor at **Procedure Library:** and select **Current**.

Position

 Procedure Library:

Select

 (The underline indicates which option is selected. Pressing knob changes the selection.)



11 Position cursor at **Code Location:** and select it.

Code Location:





PROCMA2a

Continue on next page

12 Position cursor at **Card** and select it.

Position 		Choices : ■ Card RAM Disk
Select 		

13 Position cursor at **Save Proc** and select it.

Position 		Save Proc 2 Del Proc 3 Init Card 4 Help 5 Main Menu
Select 		

14 Press **TESTS** to return to the **TESTS (Main Tests)** screen.

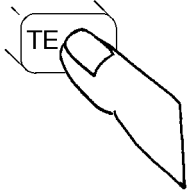

15 To run the saved procedure, follow the instructions below.

- 1) Insert the RAM card with your saved procedure.
- 2) On the **TESTS (Main Menu)** screen, a) position cursor and select **Select Procedure Location:**, then select **Card**, b) position cursor and select **Select Procedure Filename:**, then select your saved file name.
- 3) Remove your RAM card and insert the original HP 11807B ROM memory card.
- 4) Press **Run Test** .

The original card contains the full program needed to run your procedure.

PROCMA3a

Changing Test Execution Conditions

Test Execution Conditions define where and when test output occurs. You may decide to:

- Display output on CRT only, or display on CRT and print hardcopy. (**Output Results To**)

NOTE

If printing test results is desired, after selecting **Printer** additional steps are necessary to connect and configure the printer. See “[Printing](#)” on page 118.

- Display (or print) only measurements that fail, or display (or print) all measurements that pass or fail. (**Output Results For**)
- Enter a title for an output heading for the displayed or printed results. (**Output Heading**)
- Stop testing when a measurement fails or continue through all of the tests without stopping. Note: if **Stop** is selected and the program pauses as a result of this, you will be given a choice to continue testing or repeat the measurement. (**If Unit-Under-Test Fails**)
- Pause between each measurement, or run through entire test. Note: if **Single Step** is selected and the program pauses as a result of this, you will be given a choice to continue testing or repeat the measurement. (**Test Procedure Run Mode**)
- Start the program automatically when the Test System is powered on. (**Autostart Test Procedure on Power-up**)

Test Execution Conditions is accessed from the **SETUP TEST SET:** list. To change a default setting, position the cursor to the desired field. Pressing the knob (selecting) will toggle the underlined selection.

Test Execution Conditions settings are not retained after a power-down/power-up cycle, and will return to their default settings.

How to Change Test Execution Conditions

1 Press **TESTS** to display the **TESTS (Main Menu)** screen.

If you are in IBASIC, press **SHIFT, CANCEL** before pressing **TESTS**.

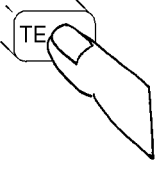

2 Position cursor at **Exec.** **Execution Cond** and select it.

Position		<div style="border: 1px solid black; padding: 2px;">Exec</div>	Execution Cond
		<div style="border: 1px solid black; padding: 2px;">Cnfg</div>	External Devices
		<div style="border: 1px solid black; padding: 2px;">Print</div>	Printer Setup
		<div style="border: 1px solid black; padding: 2px;">IBASIC</div>	IBASIC Cntrl

Select

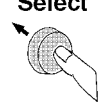

3

Select **Printer** to output test procedure results to the CRT and a printer.

Select **Failures** to display only the CRT and printer measurements that fail.

Select **Stop** to stop a Test Procedure when a failure occurs.

Select **Single Step** to stop a Test Procedure at the end of each measurement.

TESTS (Execution Conditions)

Output Results To: Crt/Printer		1 Run Test
Output Results For: All/Failures		2 Continue
Output Heading: _____		4 Help
		5 Main Menu
If Unit-Under-Test Fails: Continue/Stop		To Screen
Test Procedure Run Mode: Continuous/Single Step		RF GEN
Autostart Test Procedure on Power-Up: On/Off		RF ANL
		AF ANL
		SCOPE
		SPEC ANL
		ENCODER
		DECODER
		RADIO INT
		More

Printing and Saving Test Results

Printing and saving test results are features of the software which require additional equipment and configuration. See [“Printing” on page 118](#) for detailed descriptions and instructions for these features.

3

**RFTOOLS Library: Procedure,
Test, and Parameter Descriptions**

The RFTOOLS library contains the following tests:

- Swept Gain (page 38)
- Swept Insertion Loss (page 40)
- Swept Return Loss (page 42)
- AMPS Channel Return Loss (page 45)
- Cable Fault (page 47)
- ERP Calculator (page 53)
- Replot Data Files (page 54)
- Transfer Stored Data (page 56)
- SA Self Calibration ON/OFF (page 57)
- Catalog Memory Card (page 58)
- Create/Edit Data Collection Labels (only appears if [Parm_22 Use data collection labels \[0=No 1=Yes\]](#) is set to 1=**Yes**). See page 59.

Procedures Pre-programmed in the RFTOOLS Library

The RFTOOLS library comes pre-programmed with one procedure, also named RFTOOLS.

- Tests Included in the RFTOOLS Procedure
 - RFTOOLS Test Menu

The RFTOOLS Test Menu provides you with quick and easy access to a menu from which you may select any of RFTOOLS tests to execute. The tests are selected and run one at a time. For example, if you select **Swept Gain**, the software will immediately begin to execute it. When the selected test is completed and the results are displayed, you will be given the choice to select an additional test. You may execute the same test again, select a different test, or exit the program.

See the individual test descriptions for details on each test.

Test Descriptions

Swept Gain Test

This test measures the gain of a device by sweeping it over the specified frequency range. You will be prompted to enter the frequency range over which the device is to be swept.

This test requires two 6-dB pads. The pads are put on the antenna and duplex ports on the test set to improve the mismatch of the ports. A reference level is obtained by connecting a short calibration cable between the pads on the duplex and antenna ports. Next, the test device is added between the calibration cable and one of the pads, and a measurement is made of the additional gain from the reference level. The trace of the device gain over the frequency range swept is displayed. The maximum gain is also displayed on the screen.

Running the Swept Gain Test

1. From the RFTOOLS Test Menu, select Swept Gain.
2. Enter your desired values for the start frequency, stop frequency, plot scale in dB/div, maximum expected gain in dB, and duplex out power level in dBm.

CAUTION

To avoid overdrive damage to your device under test, ensure that you are setting an appropriately low duplex out power level.

NOTE

The default values in this list can be changed by editing Parameters 1-5 in the Edit Parameter screen. See “[RF Tools: Parameter Descriptions](#)” on page 61.

3. Press **k1** (**Begin Test**).
4. Connect the cables as instructed, and press **k2** (**Continue**).
5. If [Parm_22 Use data collection labels \[0=No 1=Yes\]](#) is set to 1=**Yes**, the software will prompt you with the option to label the data from this test. Press **k1** (**Yes**) if you want to label the data and follow the instructions on the screen for selecting or creating a label. Press **k2** (**No**) if you do not want to label the data.

6. A screen plotting the results will be displayed. You have three options:
 - Continue testing: press **k2** (**Continue**). You will have the following choices:
 - Perform the test again: press **k1** (**Repeat**).
 - Exit the test and return to the **Select Test Menu**: press **k5** (**Return**).
 - Save the plot on an SRAM card: press **k4** (**Save Plot**) and enter a filename when prompted.
 - Print a hardcopy of the graph: press **k5** (**Scr Dump**).
 - Make sure the printer is connected, and the test set is configured appropriately. The test set must be in **Control** mode if HP-IB is used.
 - Press **SHIFT, PRINT**.
 - After the print is complete, press **k2** (**Continue**).

CAUTION

Damage may result if the power input to the ANT IN port exceeds 200 mW. This can be avoided by overestimating the gain of the test device. You may enter the over-estimated gain in the Maximum expected gain in dB field on the Swept Gain Information screen, or change the default value in [Parm_04 Gain: maximum expected gain \[-50 to 20\] \(dB\)](#).

Parameters Used

- [Parm_01](#) Sweep Start Frequency [.4 to 1000 MHz]
- [Parm_02](#) Sweep Stop Frequency [.4 to 1000 MHz]
- [Parm_03](#) Gain: plot scale [1, 5, 10] (dB/div)
- [Parm_04](#) Gain: maximum expected gain [-50 to 20] (dB)
- [Parm_05](#) Gain: DUPLEX OUT level [-54 to +10] (dBm)

Swept Insertion Loss Test

This test measures the loss of a cable or device by sweeping it over the specified frequency range. You will be prompted to enter the frequency range over which the cable is to be swept.

This test requires two 6-dB pads. The pads are put on the antenna and duplex ports on the test set to improve the mismatch of the ports. A reference level is obtained by connecting a short calibration cable between the pads on the duplex and antenna ports. Next, the test cable or device is added between the calibration cable and one of the pads, and a measurement is made of the additional loss from the reference level. The trace of the cable loss over the frequency range swept is displayed. The average loss is also displayed on the screen.

Running the Insertion Loss Test

1. From the RFTOOLS Test Menu, select Insertion Loss.
2. Enter your desired values for the start frequency, stop frequency, duplex out level in dBm, and maximum expected loss in dB.

CAUTION

To avoid overdrive damage to your device under test, ensure that you are setting an appropriately low duplex out power level.

NOTE

The default values in this list can be changed by editing Parameters 1, 2, 6, and 7 in the Edit Parameter screen. See [“RF Tools: Parameter Descriptions” on page 61](#).

3. Press **k1 (Begin Tst)**.
4. Connect the cables as instructed, and press **k2 (Continue)**.
5. If [Parm_22 Use data collection labels \[0=No 1=Yes\]](#) is set to 1=**Yes**, the software will prompt you with the option to label the data from this test. Press **k1(Yes)** if you want to label the data and follow the instructions on the screen for selecting or creating a label. Press **k2 (No)** if you do not want to label the data.

6. A screen plotting the results will be displayed. You have three options:
 - a. Continue testing: press **k2** (**Continue**). You will have the choices to:
 - i. Repeat the measurement or measure another device: press **k1** (**Repeat**).
 - ii. Exit the test and return to the **Select Test Menu**: press **k5**(**Return**).
 - b. Save the plot on an SRAM card: press **k4** (**Save Plot**) and enter a filename when prompted.
 - c. Print a hardcopy of the graph: press **k5** (**Scr Dump**).
 - i. Make sure the printer is connected, and the test set is configured appropriately. Test set must be in **Control** mode if HP-IB is used.
 - ii. Press **SHIFT, PRINT**.
 - iii. After the print is complete, press **k2** (**Continue**).

Parameters Used

- [Parm_01 Sweep Start Frequency \[0.4 to 1000 MHz\]](#)
- [Parm_02 Sweep Stop Frequency \[0.4 to 1000 MHz\]](#)
- [Parm_06 Inser. loss: maximum expected \[-50 to 0\]](#)
- [Parm_07 Inser. loss: DUPLEX OUT level \[-54 to +10\]](#)

Swept Return Loss Test

NOTE

The Test Signal Can Cause Interference (Setting Duplex Out Power Level)

This test radiates a test signal when testing antennas or cables with antennas attached to them. Verify that the level and frequency span used for the test cannot result in interference to other nearby antennas. When running the program, set the duplex out power level to a minimum value for good measurement resolution. Set the frequency range carefully.

If you are a cellular operator in an area with other receive antennas nearby, you may want to use the AMPS Channel Return Loss test. This test measures the return loss at a frequency offset from a selectable range of AMPS channels. The offset (in kHz) from the AMPS channels can be set.

This test measures the return loss of a cable or device in the swept mode. A SWR bridge and a 6-dB pad are connected to the test set. The pad is used to improve the mismatch between the SWR bridge and the ANT IN port on the test set. You will be prompted at the start of the test to enter the start and stop frequencies. A reference level is measured with a short or open and the return loss is measured with the cable or antenna-under-test. The trace showing return loss over the frequency band selected is displayed on the screen. Measured values for best and worst case return loss are printed at the top of the screen. VSWR can be calculated from the return loss. The following [Table 3-1](#) contains some of the values from a calculation.

Table 3-1 Return Loss (0 to 20 dB) to VSWR

Return Loss (dB)	0	2	4	6	8	10	12	14	16	18	20
VSWR	infinity	8.7	4.4	3.0	2.3	1.92	1.67	1.50	1.38	1.29	1.22

Table 3-2 Return Loss (20 to 40 dB) to VSWR

Return Loss (dB)	20	22	24	26	28	30	32	34	36	38	40
VSWR	1.22	1.17	1.13	1.11	1.08	1.07	1.05	1.04	1.03	1.03	1.02

The following formula can be used to determine the VSWR from the return loss (=RL in dB):

$$VSWR = \frac{1 + 10^{\frac{-RL}{20}}}{1 - 10^{\frac{-RL}{20}}}$$

VSWR is sometimes stated as a ratio. For example: 1.2:1 or “one point two to one” VSWR. The first number is given in the tables and formula. The second number is always one.

Estimating Antenna Return Loss

If you are measuring the return loss of an antenna connected to the end of a known good feed line, you can determine the approximate return loss of the antenna by subtracting twice the line loss. For example, if you measure a return loss of 24 dB and the line is known to have 2 dB loss, the estimated return loss of the antenna is 20 dB. This estimate is in error if the coaxial line and connectors do not have a return loss somewhat greater than 24 dB.

Running the Swept Return Loss Test

1. From the RFTOOLS Test Menu, select Swept Return Loss.
2. Enter your desired values for the start frequency, stop frequency, duplex out level in dBm, and the maximum expected loss in dB.

NOTE

The default values in this list can be changed by editing Parameters 1, 2, 8, and 9 in the Edit Parameter screen. See [“RF Tools: Parameter Descriptions” on page 61](#).

3. Press **k1** (**Begin Tst**).
4. Connect the cables as instructed, and press **k2** (**Continue**).
5. If [Parm_22 Use data collection labels \[0=No 1=Yes\]](#) is set to 1=**Yes**, the software will prompt you with the option to label the data from this test. Press **k1** (**Yes**) if you want to label the data and follow the instructions on the screen for selecting or creating a label. Press **k2** (**No**).

if you do not want to label the data.

Test Descriptions

6. A screen plotting the results will be displayed. You have three options:
 - Continue testing: press **k2** (**Continue**). You will have the following choices:
 - Perform the test again: press **k1** (**Repeat**).
 - Exit the test and return to the **Select Test Menu**: press **k5** (**Return**).
 - Save the plot on an SRAM card: press **k4** (**Save Plot**) and enter a filename when prompted.
 - Print a hardcopy of the graph: press **k5** (**Scr Dump**).
 - Make sure the printer is connected, and the test set is configured appropriately. Test set must be in **Control** mode if HP-IB is used.
 - Press **SHIFT, PRINT**.
 - After the print is complete, press **k2** (**Continue**).

Parameters Used

- **Parm_01** Sweep Start Frequency [.4 to 1000 MHz]
- **Parm_02** Sweep Stop Frequency [.4 to 1000 MHz]
- **Parm_08** Return loss: maximum expected [-50 to 0]
- **Parm_09** Return loss: DUPLEX OUT level [-54 to +10]

AMPS Channel Return Loss Test

This test measures the return loss in a device for discrete cellular AMPS channel frequencies. This test is performed at channels entered by the user and offset by a frequency to make the measurement between actual channels. A reference level is measured on the spectrum analyzer with a short or open on the SWR bridge DUT port. The return loss is then measured with the cable or antenna-under-test on the SWR bridge DUT port.

This test should be used when there is a chance that a full frequency sweep of the band to be tested may cause interference. In this test, the chance of interference is greatly reduced by selecting an offset that sets a CW test frequency between the assigned AMPS channels. For example, selecting an offset of 15 kHz places the test signal between adjacent AMPS channels and adjacent NAMPS channels.

See “[Swept Return Loss Test](#)” on page 42 description for a return loss to VSWR conversion table and formula and a way to estimate the return loss of an antenna connected to the end of a feed line.

Running the AMPS Channel Return Loss Test

1. From the RFTOOLS Test Menu, select AMPS Channel Return Loss.
2. Enter your desired values for the start channel, stop channel, step channel, offset frequency in MHz, band RX or TX, and duplex out level in dBm.

CAUTION

To avoid overdrive damage to your device under test, ensure that you are setting an appropriately low duplex out power level.

NOTE

The default values in this list can be changed by editing Parameters 10-15 in the Edit Parameter screen. See “[RF Tools: Parameter Descriptions](#)” on page 61.

3. Press **k1 (Begin Test)**.
4. Connect the cables as instructed, and press **k2 (Continue)**.
5. Measurement results will be displayed. Press **k1 (Repeat)** if you want to repeat the measurement or measure another device. Press **k5 (Return)** if you want to exit this test.

Parameters Used

- Parm_10 Discrete return loss: start chan [AMPS]
- Parm_11 Discrete return loss: stop chan [AMPS]
- Parm_12 Discrete return loss: channel step size
- Parm_13 Discrete return loss: off freq [0 to 20]
- Parm_14 Discrete return loss: band [0=FWD 1=REV]
- Parm_15 Discrete return loss: DUPLEX OUT [-54 to +10]

Cable Fault Test

NOTE

The Test Signal Can Cause Interference

When testing cables attached to antennas, test signals will be radiated. Verify that the signal used for the test cannot result in interference to another antenna. The software reduces the signal generator's level except when it is needed to actually perform the measurement.

This test operates over a wide frequency band. The test will always operate with a center frequency of 505 MHz. The frequency span however will be determined by the length of the cable measured. Longer cables will use a narrower frequency span. The frequency span will equal 990 MHz for cables less than 50 feet long and equal approximately 99 MHz for cables 500 feet long. It is always safe to assume that the frequency span is less than or equal to 990 MHz.

This test displays the return loss of a transmission line as a function of the distance down the line. A frequency-swept signal from the DUPLEX OUT port is applied through a resistive power divider to the cable-under-test. Signals reflected from faults in the cable are combined with the DUPLEX OUT signal in the power divider and applied to the ANT IN port. The changing interference of the forward and reflected signals, over the swept frequency band, contains information about the distance to one or more faults. The software uses a Fast Fourier Transform (FFT) to convert the frequency domain into the distance domain. The distance displayed on the test set's CRT is the physical distance to the fault with correction for the velocity factor of the cable.

Cable Fault Performance

Measurements of the cable fault location can typically be made up to 500 feet on low-loss cables and 300 feet on higher-loss cables. Resolution of the fault location is approximately 0.4 feet for cable lengths up to 50 feet and then linearly increases to 4 feet for a 500 foot cable.

Selecting Cable Type

When this test is run, a screen will appear which will prompt you for the following information:

- Cable length
- Cable length units
 - Pressing the knob will toggle the selection between feet and meters.
- Cable class
 - Pressing the knob will provide for Heliax, RG, and custom options.
- The next prompt varies depending on the selection for cable class:
 - If Custom is selected, you will be prompted to enter the cable's velocity of propagation constant and attenuation per 100 feet (or meters). The propagation velocity must be a value between 0 and 1.
 - If RG is selected, you will be prompted to enter the cable type with the example [RG 58/U = 58]. You must enter a value between 0 and 1000.
 - If Heliax is selected, you will be prompted to enter the cable type. A list will appear with choices of foam, air, and flex of varying thickness. Push the knob to select the desired cable type.
- Select **Begin Test** when all the appropriate entries have been made.
- Connect the cables as instructed, and press **k2 (continue)**.

NOTE

The default values in this list can be changed by editing Parameters 16-21 in the Edit Parameter screen. See [“RF Tools: Parameter Descriptions” on page 61](#).

NOTE

Velocity Factors And Attenuation

Cables that use polyethylene dielectric typically have a propagation velocity of 0.66, cables that use a teflon dielectric typically have a propagation velocity of 0.70. If the cable attenuation is unknown, enter 0 dB per 100 feet (or meters). Entering 0 dB/100 will produce return loss values lower than actual, but fault distance can be accurately detected.

NOTE

Typical Cable Fault Return Loss Measurements

Return loss is a ratio of input power to reflected power. For example, if 100 Watts was applied to a cable and 10 Watts was returned, the return loss is 10 dB ($10 \log (100/10)$). In the same example, if 1 Watt was returned, the return loss would be 20 dB ($10 \log (100/1)$). Typical return loss measurements for the cable loss test are listed below:

- Open-Circuit Cable = 0 dB
- Short-Circuit Cable = 0 dB
- 50-Ohm Terminated Cable = 20 to 30 dB
- Antenna = 10 to 20 dB

Return loss measurements below 25 dB should be considered excellent. For best results, the cable output should be terminated in 50 ohms.

Entering Cable Length

The greatest accuracy is obtained when you enter a cable length slightly greater than the actual cable length, considering length uncertainty. If you are not sure of the cable length, enter a value 1.5 times the estimated length. Depending on the return loss of the antenna or device at the end of the cable, you may see a high relative mismatch displayed at the actual length of the cable.

NOTE

Parm_18 Cable fault: [0=RG 1=HELIAX 2=Custom] selects the cable class. **Parm_19 Cable type:** [1>13 for Heliax, # for RG] sets the type of cable to be measured. If the cable is 'RG', enter the RG type in parm_19 (for example: for type RG 58/U, enter 0=RG in parm_18, and "58" in parm_19). If the cable is **Heliax**, enter the number corresponding to the list below in parm_19. If the cable is **Custom**, use parameters 20 and 21 to enter the cable attenuation and propagation velocity.

HELIAX Cable Types

1. 3/8 foam
2. 1/2 foam
3. 7/8 foam
4. 1 1/4 foam
5. 1 5/8 foam
6. 1/2 air
7. 5/8 air
8. 7/8 air
9. 1 5/8 air
10. 2 1/4 air
11. 1/4 flex
12. 3/8 flex
13. 1/2 flex

Running the Cable Fault Test

1. From the RFTOOLS Test Menu, select Cable Fault.
2. Enter your desired values for the cable length, cable length units, cable class, and cable type (see “[Selecting Cable Type](#)” on page 48).

NOTE

The default values in this list can be changed by editing parameters 16-21 in the Edit Parameter screen.

3. Press **k1 (Begin Tst)**.
4. Connect the cables as instructed, and press **k2 (Continue)**.
5. If [Parm_22 Use data collection labels \[0=No 1=Yes\]](#) is set to 1=**Yes**, the software will prompt you with the option to label the data from this test. Press **k1 (Yes)** if you want to label the data and follow the instructions on the screen for selecting or creating a label. Press **k2 (No)** if you do not want to label the data.
6. A screen plotting the results will be displayed. You have three options:
 - a. Continue testing: press **k2 (Continue)**. You will have the choices to:
 - i. Perform the test again: press **k1 (Repeat)**.
 - ii. Display the numerical data values: press **k3 (Disp Data)**.
 - a. To return to the plot, press **k3 (Plot Data)**.
 - ii. Exit the test and return to the **Select Test Menu**: press **k5 (Return)**.
 - b. Save the plot on an SRAM card: press **k4 (Save Plot)** and enter a filename when prompted.
 - c. Print a hardcopy of the graph: press **k5 (Scr Dump)**.
 - i. Make sure the printer is connected, and the test set is configured appropriately. Test set must be in **Control** mode if HP-IB is used.
 - ii. Press **SHIFT, PRINT**.
 - iii. After the print is complete, press **k2 (Continue)**.

Parameters Used

- Parm_16 Cable fault: cable length
- Parm_17 Cable fault: length units [0=ft 1=m]
- Parm_18 Cable fault: [0=RG 1=HELIAX 2=Custom]
- Parm_19 Cable type: [1>13 for Heliax, # for RG]
- Parm_20 Cable fault: custom cable attenuation (dB/unit)
- Parm_21 Cable fault: custom cable prop. velocity (<1.0)

Interpreting Cable Fault Location Results

Distance to the cable fault is accurately quantified when you select the **USER Disp data** field. The return loss levels and distance at which the faults occur are displayed. Numeric data for the six smallest return loss values of data from the graph are listed. Values greater than 25 dB can be ignored. The smallest return loss is most likely the location of a cable fault. Other numeric data points, particularly if they are further down the line from a point of high relative mismatch, can be ignored. Data points on the fringe of a point of high relative mismatch are usually attributable to the single fault.

ERP Calculator

This test automatically calculates ERP (effective radiated power), when you enter the data for the following variables:

- Input Power
- Feed Cable Loss
- Antenna Gain

This test also allows you the option to enter the ERP and two other variables to automatically calculate the third. (For example, you may enter the values for ERP, Input Power, and Feed Cable Loss. The software will calculate the Antenna Gain).

You may select from the following three options for the units of power displayed:

- dBm
- Watts
- dBw

The software uses the following equation to make the calculations described above:

$$\text{ERP}_{\text{dBW}} = \text{Input Power}_{\text{dBW}} - \text{Feed Loss}_{\text{dB}} + \text{Antenna Gain}_{\text{dB}}$$

Running the ERP Calculator Test

1. From the RFTOOLS Test Menu, select ERP Calculator.
2. Position the cursor to the **Item to be calculated** field and select it.
 - a. Select the variable you wish the software to calculate. The choices are ERP, Input power, Feed cable loss, and Antenna gain.
3. Position the cursor to the **Units** field and select the desired units:
 - a. A list will appear with the following choices: Watts, dBW and dBm.
4. Enter the values for the three known variables.
5. The software will automatically calculate the unknown variable.

Parameters Used

- No parameters are used in this test.

Replot Data Files

This test allows you to easily retrieve and display plots which were previously stored on an SRAM card. One or two plots may be displayed at one time.

No measurements are performed.

For information on how to store plot data on an SRAM card, see descriptions of “Swept Gain Test” on page 38, “Swept Insertion Loss Test” on page 40, “Swept Return Loss Test” on page 42, and “Cable Fault Test” on page 47.

Displaying One Plot at a Time

1. From the RFTOOLS Test Menu, select Replot Data Files.
2. Insert the memory card containing the plot data files.
3. Files saved on the card will be listed below the double line. Select the **select files to replot** field.
4. Select the plot file(s) you wish to display (if you select more than one, they will be displayed consecutively with a pause in between).
5. Press **k5 (Return)**.
6. Select the **Replot files selected below** field.
 - ✓ A screen plotting the results will be displayed. You have three options:
 - Continue the procedure: press **k2 (Continue)**. If you selected more than one plot, the next will be displayed. Otherwise, you will have the following choices:
 - Exit the test and return to the **Select Test Menu**: press **k5 (Exit Test)**.
 - Select additional files to replot.
 - Store the plot on an SRAM card: press **k4 (To Card)** and enter a filename when prompted.
 - Print a hardcopy of the graph: press **k5 (Scr Dump)**.
 - Make sure the printer is connected, and the test set is configured appropriately. Test set must be in **Control** mode if HP-IB is used.
 - Press **SHIFT, PRINT**.
 - After the print is complete, press **k2 (Continue)**.
 - ✓ If you would like to delete plot files from the card, select **Purge (Delete) Selected Files**.
 - ✓ Press **k5 (Exit Test)** to exit.

Displaying Two Plots on One Screen at the Same Time

1. From the RFTOOLS Test Menu, select Replot Data Files.
2. Insert the memory card containing the plot data files.
3. Select the **Plot two files on one screen** field.
4. Select the **Legend location** field, and select the desired location for the plot reference key. When the plots are displayed, the key covers part of the graph. Choose the location that will least interfere with viewing your plot. The selections toggle between top and bottom.
5. Select the **Primary plot file name** field. The list of files stored on the memory card will appear. The files ending with **_p** (or **.PLT** for HP11807E) represent plot files. The primary plot data determines the scale for the graph.
6. Select your desired primary data file.
7. Select the **Secondary plot file name** field. The list of files stored on the memory card will again appear.
8. Select your desired secondary data file.
9. Press **k1 (Plot)**. A screen plotting the results will be displayed. You have three options:
 - Move the legend: press **k4 (Legend)** to refresh the screen, moving the legend to the alternate location.
 - Continue the procedure: press **k2 (Continue)**. You will have the following choices:
 - Return to the **RFTOOLS Test Menu**: press **k5 (Return)**.
 - Select additional files to plot.
 - Print a hardcopy of the graph: press **k5 (Scr Dump)**.
 - Make sure the printer is connected, and the test set is configured appropriately. Test set must be in **Control** mode if HP-IB is used.
 - Press **SHIFT, PRINT**.
 - After the print is complete, press **k2 (Continue)**.

Parameters Used

- No parameters are used in this test.

Transfer Stored Data

This test may be used to easily transfer data collection (test results) files from an SRAM card over the serial or HP-IB port. You do not need to write an IBASIC program. No measurements are performed.

Transferring Stored Data

1. From the RFTOOLS Test Menu, select Transfer Stored Data.
2. Insert the memory card containing the test results.
3. Select the appropriate output port: a list will appear with the selections serial port, parallel port and HP-IB, Addr 701.
4. Make sure the appropriate cables are connected, and serial or HP-IB settings are correct on the I/O Configure screen (**To Screen** menu, select **More**, **IO CONFIG**).
5. Files saved on the card will be listed below the double line. Select the files you wish to transfer.
 - Select the files you would like to transfer. An asterisk will appear after the selected files.
 - Press the **Select/Deselect Files [*=Selected]** field.
 - Select **Return to menu**.
6. Select **Transfer Selected Files**.
7. Once the files are transferred, if you would like to delete the files from the card, select **Purge (Delete) Selected Files**.
8. Press **k5 (Return)** to return to the RFTOOLS Test Menu.

Parameters Used

- [Parm_23 Show all data files \[0=No 1=Yes\]](#)

SA Self Calibration ON/OFF

This test allows you to check the status of the test set's spectrum analyzer, and change the status if you desire.

The RFTOOLS program uses the test set's internal spectrum analyzer for making network analyzer measurements. The internal spectrum analyzer performs an automatic self calibration every 5 minutes. This automatic self calibration insures that the spectrum analyzer operates within specified limits regardless of the operating temperature. However, this self calibration can introduce instability in spectrum analyzer output after the test set is operating at a constant temperature (after approximately 30 minutes).

Each RFTOOLS test includes two parts; calibration and measurement. If the spectrum analyzer performs a self calibration between the calibration and measurement of the RFTOOLS test, the spectrum analyzer automatic self calibration instability will increase RFTOOLS test measurement error. To avoid this problem, you may use this test to turn off the spectrum analyzer self calibration. This self calibration should only be turned off after the unit has reached a constant powered-on operating temperature (approximately 30 minutes after power-on). By turning the self calibration off, the measurement accuracy and stability of RFTOOLS tests will improve.

Catalog Memory Card

This test lists all the files contained on the memory card. The memory card that you wish to catalog must be inserted prior to selecting this test.

LIF file types are denoted by the following prefixes and suffixes:

- **c** prefix denotes a program code file
- **l** prefix denotes a library file
- **p** prefix denotes a procedure file
- **_d** suffix denotes a data file
- **_p** suffix denotes a plot file

DOS file types are denoted by the following suffixes:

- **.PGM** suffix denotes a program code file
- **.LIB** suffix denotes a library file
- **.PRC** suffix denotes a procedure file
- **.DAT** suffix denotes a data file
- **.PLT** suffix denotes a plot file

Parameters Used

- No parameters are used in this test.

Create/Edit Data Collection Labels

This test will only appear on the RFTOOLS Test Menu, if [Parm_22 Use data collection labels \[0=No 1=Yes\]](#) is set to 1=**Yes**. If this parameter is set to 1=**Yes**, before performing the measurement the software will prompt: **Would you like to label the data from this test?**. If you press **k1 (Yes)**, the software will prompt you with the following choices:

- Return to testing without labeling data (in case you pressed **Yes** by mistake).
- Enter label manually, and select label from a list.

This test allows you to create and edit files containing up to 50 labels to be stored on an SRAM card. These labels can be used later for labeling test output, in conjunction with the data collection function. Data collection allows you to store all the test data in a file which is named at the beginning of the test procedure. Data collection labels allow you to label each individual measurement. Data collection label files are stored under the filename **uLAB_#**, where # can be any value between 1 and 999.

When test results are stored to a data collection file, (sent to a PC or printer) it may be convenient to separate the data by labeling each measurement. For example, you may want to test the insertion loss of several test cables without repeating the calibration step in between measurements. The first five tests on the RFTOOLS Test Menu permit repetitive testing after initial calibrations are performed.

There are two ways to create data collection labels: using this test to create and store the labels, or waiting until you have a measurement that you would like to label and creating it then. For either method, you must set [parm_22 Use data collection labels \[0=No 1=Yes\]](#) to 1=**Yes**. If you would like to use the same label(s) several times, it would be useful to run this test to create the labels and store them in a file which can be retrieved when desired. If it is not likely that you will use the same label several times, but you would still like to label the test output, you may do so when prompted.

Labels can be entered using the characters in the **Choices** menu, or by using a terminal emulator program. See [“Collection to a PC” on page 100](#) for information on setting up a terminal emulation program.

Creating/Editing Data Collection Labels

1. From the RFTOOLS Test Menu, select Create/Edit Data Collection Labels.
2. A screen will appear with the following choices:
 - Return to the previous menu
 - This selection will return you to the RFTOOLS Test Menu.
 - Select label filename
 - This field is used to create or retrieve the data collection label filename. Label files are stored as uLAB_#, where # is the number entered in this field.
 - Store labels to file
 - This selection will store the label file to the inserted smart card, under the current filename (see field above).
 - Purge label file
 - This selection will delete the current label file from the smart card.
 - Edit labels shown below
 - This selection will allow access (for editing) to the labels that appear below the double line.
 - Below the double line, fields labeled L1-L50 appear.
 - Scroll the cursor to these fields to enter your desired labels. Up to fifty labels can be stored for each location. Use k2 (**Page Up**) and k4 (**Page Down**) to quickly scroll through this list if necessary. (This list is accessed by selecting the **Edit labels shown below** field, described above).
 - Press k5 (**Return**) to return to the menu above the double line.
3. Select the **Edit labels shown below** field.
4. Enter your desired labels.
5. Press k5 (**Return**).
6. Select the **Select label file name** field. Remember that this number will be used to retrieve the file when desired.
7. Select the **Store labels to file** field. You will be prompted with “Do you want to store data collection labels to uLAB_#?” Select k1(**Yes**) if you would like to continue.
8. Press k5 (**Return**).

Parameters Used

- [Parm_22 Use data collection labels \[0=No 1=Yes\]](#)

RF Tools: Parameter Descriptions

Parameters are used to define the conditions under which a test will run. You may edit the parameters to change the default values, to meet your specific testing needs and conditions. Parameters may be used in one or more tests.

For information on editing parameters, see [“Customizing Testing” on page 20](#).

Parm_01 Sweep Start Frequency [.4 to 1000 MHz]

Enter the starting frequency for swept tests (tests 1 through 3). If the start frequency is less than 2 MHz, the frequency span (Parm_02 and Parm_01) must be less than 10 MHz.

This entry will appear as the default on the sweep information menu each time a swept test begins to run. You have the option to use the menu to change this value for the current test.

Parm_02 Sweep Stop Frequency [.4 to 1000 MHz]

Enter the stopping frequency for swept tests (tests 1 through 3). The stop frequency must be greater than the start frequency (entered in parm_01).

This entry will appear as the default on the sweep information menu each time a swept test begins to run. You have the option to use the menu to change this value for the current test.

Parm_03 Gain: plot scale [1, 5, 10] (dB/div)

Enter the desired plot scale for the Swept Gain test. This entry will appear as the default on the swept gain information menu each time the swept gain test begins to run. You have the option to use the menu to change this value for the current test.

Parm_04 Gain: maximum expected gain [-50 to 20] (dB)

Enter the maximum expected gain for the Swept Gain test. This parameter sets the expected worst case power for the ANT IN port. It is very important to overestimate the expected gain to avoid damage to the ANT IN port.

This parameter is also used to set the plot resolution (top value of the plot).

This entry will appear as the default on the swept gain information menu each time the swept gain test begins to run. You have the option to use the menu to change this value for the current test.

Parm_05 Gain: DUPLEX OUT level [-54 to +10] (dBm)

Enter the desired DUPLEX OUT level for the Swept Gain test. If you are testing a power sensitive device, be sure to enter an appropriately low level to avoid damage.

This entry will appear as the default on the swept gain information menu each time the swept gain test begins to run. You have the option to use the menu to change this value for the current test.

Parm_06 Inser. loss: maximum expected [-50 to 0]

Enter the maximum expected loss for the Swept Insertion Loss test. This parameter is used to set the plot resolution (the bottom limit of the plot).

This entry will appear as the default on the swept insertion loss information menu each time the swept insertion loss test begins to run. You have the option to use the menu to change this value for the current test.

Parm_07 Inser. loss: DUPLEX OUT level [-54 to +10]

Enter the desired DUPLEX OUT level for the Swept Insertion Loss test. If you are testing a power sensitive device, be sure to enter an appropriately low level to avoid damage.

This entry will appear as the default on the swept insertion loss information menu each time the swept insertion loss test begins to run. You have the option to use the menu to change this value for the current test.

Parm_08 Return loss: maximum expected [-50 to 0]

Enter the maximum expected loss for the Swept Return Loss test. This parameter is used to set the plot resolution (the bottom limit of the plot).

This entry will appear as the default on the swept return loss information menu each time the swept return loss test begins to run. You have the option to use the menu to change this value for the current test.

Parm_09 Return loss: DUPLEX OUT level [-54 to +10]

Enter the desired DUPLEX OUT level for the Swept Return Loss test. If you are testing a power sensitive device, be sure to enter an appropriately low level to avoid damage.

This entry will appear as the default on the swept return loss information menu each time the swept return loss test begins to run. You have the option to use the menu to change this value for the current test.

Parm_10 Discrete return loss: start chan [AMPS]

Enter the desired AMPS channel on which to begin testing for the AMPS Channel Return Loss test. The appropriate channel ranges are 1 to 799 and 991 to 1023.

This entry will appear as the default on the AMPS channel return loss information menu each time the AMPS channel return loss test begins to run. You have the option to use the menu to change this value for the current test.

Parm_11 Discrete return loss: stop chan [AMPS]

Enter the desired AMPS channel on which to stop testing for the AMPS Channel Return Loss test. The appropriate channel ranges are 1 to 799 and 991 to 1023.

This entry will appear as the default on the AMPS channel return loss information menu each time the AMPS channel return loss test begins to run. You have the option to use the menu to change this value for the current test.

Parm_12 Discrete return loss: channel step size

Enter the desired step size for the AMPS Channel Return Loss test. The test will begin on the channel entered in parm_10, and will increment by the value entered in this parameter until the stop channel number (parm_11) is reached.

This entry will appear as the default on the AMPS channel return loss information menu each time the AMPS channel return loss test begins to run. You have the option to use the menu to change this value for the current test.

Parm_13 Discrete return loss: off freq [0 to 20]

Enter the desired offset frequency for the AMPS Channel Return Loss test.

This entry will appear as the default on the AMPS channel return loss information menu each time the AMPS channel return loss test begins to run. You have the option to use the menu to change this value for the current test.

Parm_14 Discrete return loss: band [0=FWD 1=REV]

Enter the desired transmit band for the AMPS Channel Return Loss test. Selecting 0=FWD selects the forward channel, and selecting 1=REV selects the reverse channel.

Parm_15 Discrete return loss: DUPLEX OUT [-54 to +10]

Enter the desired DUPLEX OUT level for the AMPS Channel Return Loss test. If you are testing a power sensitive device, be sure to enter an appropriately low level to avoid damage.

This entry will appear as the default on the AMPS channel return loss information menu each time the AMPS channel return loss test begins to run. You have the option to use the menu to change this value for the current test.

Parm_16 Cable fault: cable length

Enter the length of the cable under test for the Cable Fault test. (Units are selected in parm_17 Cable fault: length units. The greatest accuracy is obtained when you enter a cable length slightly greater than the actual cable length. If you are not sure of the cable length, enter a value 1.5 times the estimated length.

This entry will appear as the default on the cable fault information menu each time the cable fault test begins to run. You have the option to use the menu to change this value for the current test.

Parm_17 Cable fault: length units [0=ft 1=m]

Enter the desired units for the cable length for the Cable Fault test. The parameter is used together with parm_16 Cable fault: length which sets the actual value for the length.

This entry will appear as the default on the cable fault information menu each time the cable fault test begins to run. You have the option to use the menu to change this value for the current test.

Parm_18 Cable fault: [0=RG 1=HELIAX 2=Custom]

Enter the desired class for the cable used in the Cable Fault test. If 0=**RG** or 1=**HELIAX** is selected, you must enter the cable type in parm_19 Cable type. If 2=**Custom** is selected, you must enter the cable attenuation in parm_20, and the cable propagation velocity in parm_21. This entry will appear as the default on the cable fault information menu each time the cable fault test begins to run. You have the option to use the menu to change this value for the current test.

Parm_19 Cable type: [1>13 for Heliax, # for RG]

If parm_18 Cable fault: [0=RG 1=HELIAX 2=Custom] is set to 0=RG, enter the appropriate type number (for example: for type RG 58/U, enter 0=RG in parm_18, and "58" in parm_19).

If parm_18 is set to 1=HELIAX, enter the number corresponding to the list below.

HELIAX Cable Types

1. 3/8 foam
2. 1/2 foam
3. 7/8 foam
4. 1 1/4 foam
5. 1 5/8 foam
6. 1/2 air
7. 5/8 air
8. 7/8 air
9. 1 5/8 air
- 10.2 1/4 air
- 11.1/4 flex
- 12.3/8 flex
- 13.1/2 flex

This entry will appear as the default on the cable fault information menu each time the cable fault test begins to run. You have the option to use the menu to change this value for the current test.

Parm_20 Cable fault: custom cable attenuation (dB/unit)

If parm_18 Cable fault: [0=RG 1=HELIAX 2=Custom] is set to 2=Custom, enter the cable's attenuation per 100 feet (or meters). If the cable attenuation is unknown, enter 0 dB per 100 feet (or meters). This will produce return loss values lower than actual, but fault distance can be accurately detected.

This entry will appear as the default on the cable fault information menu each time the cable fault test begins to run (if parm_18 is set to 2=Custom). You have the option to use the menu to change this value for the current test.

Parm_21 Cable fault: custom cable prop. velocity (<1.0)

If parm_18 Cable fault: [0=RG 1=HELIAX 2=Custom]

is set to 2=**Custom**, enter the cable's propagation velocity. This must be a value which is less than one. Typically, cables that use polyethylene dielectric have a propagation velocity of 0.66, and cables that use a teflon dielectric typically have a propagation velocity of 0.70.

This entry will appear as the default on the cable fault information menu each time the cable fault test begins to run (if parm_18 is set to 2=**Custom**). You have the option to use the menu to change this value for the current test.

Parm_22 Use data collection labels [0=No 1=Yes]

This parameter performs two functions:

- Determines whether the **Create/Edit Data Collection Labels** test will appear on the RFTOOLS Test Menu.
- Allows the user to label individual test results.

If this parameter is set to 1=**Yes**, before performing the measurement the software will prompt: **Would you like to label the data from this test?** If you press **k1 (Yes)**, the software will prompt you with the following choices:

- Return to testing without labeling data
 - in case you pressed **Yes** by mistake
- Enter label manually
 - You may enter a label for this measurement only (the label will not be stored for future use)
- Select label from a list
 - You may retrieve a file containing labels that you previously created and stored from the **Create/Edit Data Collection Labels** test.

If this parameter is set to 0=**No**, you will not be prompted with a choice to label the data, and the **Create/Edit Data Collection Labels** test will not appear on the RFTOOLS Test Menu.

Parm_23 Show all data files [0=No 1=Yes]

This parameter determines which files appear when cataloging a memory card (running the Transfer stored data test). If this parameter is set to 0=**No**, only data files will be listed. If this parameter is set to 1=**Yes**, all the files contained on the memory card will be listed, including all data, procedure, library and program files.

4

FIELD_S Library: Procedure, Test, and Parameter Descriptions

The FIELD_S library contains the following tests:

- [TEST_01 Measure Test Plan](#)
- [TEST_02 Print Stored Measured Data](#)

Procedures Pre-programmed in the FIELD_S Library

The FIELD_S library comes pre-programmed with one procedure, also named FIELD_S.

- Tests Included in the FIELD_S Procedure
 - TEST_01 Measure test plan
 - TEST_02 Print stored measured data

The Field-Strength Measurement procedure measures field strength for a specific user-defined “measurement plan.” A measurement plan contains up to 22 frequencies that can be measured at up to 22 different locations, or on the test set in minimum, peak, and average power for each frequency at the given location.

Setting Up Test Frequencies for the FIELD_S Library

1. Press TESTS.
2. Select **Card** in the **Select Procedure Location:** (or **Location:**) field.
3. Select the procedure **FIELD_S**.
4. Select **FreqChannel Information** from the **CUSTOMIZE TEST PROCEDURE** list (or **Edit Freq** from the **Test Function** field).
5. Select the inverse-video box in the **Chan#** column. Turn the knob until the desired frequency (or position in the column) you want is displayed in an inverse-video box, then push the knob to clear the cursor from the **Chan#** field.
6. Select the upper inverse-video field in **Col A Freq** (right column) or **Col B Freq** (left column), depending upon which frequency you want to change. Key in the desired frequency in MHz.

The program can measure up to 22 frequencies. Enter frequencies in the left, right, or both columns. However, when the program is running, frequencies are measured sequentially from left to right, top to bottom.

Setting Up Measurement Locations

7. Select the lower inverse-video field in **Col A Freq** (left column) or **Col B Freq** (right column) and enter a descriptive “location label” for each measurement location (of up to 12 letters or numbers). Location labels are displayed when the program is run to identify the site or **Measure location**. The program can store up to 22 different measurement locations. Enter locations in the left, right, or both columns when the program is running. Measurement locations are chosen in sequence from left to right, top to bottom.

The frequencies and measurement locations you enter are independent data. For each measurement location you specify, the program will step through all of the frequencies entered and store the field strength level data.

8. Press k5 (**Main Menu**) (or TESTS) when you are done.

NOTE

The test frequency and location settings you created should be saved into a procedure if desired. Refer to [Chapter 2](#), “[Loading and Running the Software](#),” on [page 13](#). If you do not save the settings into a procedure, the information will reset to the defaults when you select a new procedure.

NOTE

If you have firmware below revision A.14.00, the Test? and Prime? fields are not used by the FIELD_S library. The software ignores any entries in these fields. Firmware above revision A.14.00 does not display these fields.

Test Descriptions

Tests are a series of measurements and one or more tests make up a procedure (see [Chapter 2](#), “Loading and Running the Software,” on [page 13](#)). While you may change the tests that make up a procedure, you may not change the measurements the test will perform. Generally, the order in which the tests are run is not important.

TEST_01 Measure Test Plan

This test measures the field strength for each frequency and location that you specify. The software reports measurements for the peak value, minimum value, and average value. At the end of each measurement, the user has the option to store data onto an SRAM memory card under any file name you choose.

Running the Measure Test Plan

1. Connect an antenna to the test set’s ANT IN connector.
2. Test frequencies in the **Channel Information** (or Edit Freq) screen must be correctly set for the **FIELD_S** program before you proceed.
3. Run TEST_01 Measure Test Plan.
4. A listing of the locations in the frequency table will be displayed. Use the knob to select the location to measure.
5. Take the test set to the measurement site and select **k1 (Measure)** field to start the measurement. Measurements are made for the location selected.
6. When the measurement is done, insert an initialized SRAM memory card into the test set, and select **k2 (Save)**.
7. Push the knob and enter a file name (maximum of 9 characters in length) for saving the measurement results.
8. After saving the test results, you will have three options:
 - Repeat the measurement, press **k1 (Measure)**.
 - Select a new location to measure, press **k3 (Sel Loc)**.
 - Quit the test, press **k5 (Quit)**.

Parameters Used

- Parm_01 Antenna Gain (dB)
- Parm_02 Number of times to average reading

TEST_02 Print Stored Measured Data

This test allows you to print the measured results from [TEST_01 Measure Test Plan](#). The measured results may be sent to a printer or to the test set's display. For information on how to set up a printer, see [Chapter 8 , "Reference \(Alphabetical\)," on page 93](#).

Printing the Stored Data

1. When the measurement routine is done (and you've pressed **k5 (Quit)**), **TEST_02** starts and you are prompted to "**select the file to print**". The test set displays all of the available files from the currently inserted memory card.

Rotate the knob to point the arrow to the file you want. Then press the knob to select it.

If the **Test Output Location** field on Test Execution Conditions screen is set to **CRT**, the measurement data will be displayed on the test set's CRT. If the field is set to **Printer**, the measurement data will be sent to both the CRT and a properly configured external printer.

2. You are prompted to select **k2 (Continue)** to display (or print) all of the measurement data.
3. When all of the measurement data is displayed (or printed) you are prompted to "**view another file?**". Select **Yes** or **No**.
4. Press the **TESTS** key when you are finished.

Parameters Used

- There are no parameters used in this test.

Field Strength Test: Parameter Descriptions

Parameters are used to define the conditions under which a test will run. You may edit the parameters to change the default values, to meet your specific testing needs and conditions. Parameters may be used in one or more tests.

For information on editing parameters, see [“Customizing Testing” on page 20](#).

Parm_01 Antenna Gain

Enter the gain of the antenna used to perform [TEST_01 Measure Test Plan](#).

Parm_02 Number of times to average reading

Enter the number of data points to be used to compute the average field strength value in [TEST_01 Measure Test Plan](#).

5

INTRMOD Library: Procedure, Test, and Parameter Descriptions

The INTRMOD library contains the following tests:

- [TEST_01 Calculate Intermods](#)

Procedures Pre-programmed in the INTRMOD Library

The INTRMOD library comes pre-programmed with one procedure, also named INTRMOD.

- Tests Included in the INTRMOD Procedure
 - [TEST_01 Calculate Intermods](#)

Test Descriptions

TEST_01 Calculate Intermods

Intermodulation Products Theory of Operation

Intermodulation products are calculated beginning with the first three transmit frequencies (f_1 , f_2 , and f_3) given by the following formulas:

2nd order product frequencies = $f_1 \pm f_2$

3rd order product frequencies (2 TX Freqs) = $f_1 \pm 2f_2$, $2f_1 \pm f_2$

3rd order product frequencies (3 TX Freqs) = $f_1+f_2-f_3$, $f_3+f_1-f_2$, $f_2+f_3-f_1$

5th order product frequencies = $2f_1 \pm 3f_2$, $3f_1 \pm 2f_2$,

Then, f_1 is checked against $f_3, f_4 \dots f_{20}$

Then, f_2 is checked against $f_3, f_4 \dots f_{20}$

Then, f_3 is checked against $f_4, f_5 \dots f_{20}$

This process continues on through the remaining transmit frequencies. As the **INTRMOD** program is calculating, the program can check all intermodulation products to see if they exactly match the specified receive frequency or the upper and lower adjacent channels. If a match is found, it is displayed as 2nd, 3rd, or 5th order products.

Setting Up Intermodulation Products Parameters

1. Press TESTS.
2. Select **Card** in the **Select Procedure Location: (or Location:)** field.
3. Select the test procedure **INTRMOD**.
4. Set **parm_1** to the exact frequency, in MHz, that you are concerned intermodulation frequencies are affecting. (Most likely it will be a receive (RX) frequency.)
5. Select **ParmTest Parameters** from the **Customize Test Procedure** list (or **Edit Parm** from the **Test Function** field).
6. Set **parm_2** through **parm_21** to the transmitter frequencies in MHz that could be causing intermodulation products. (If you are setting less than 20 transmit frequencies, always start with **parm_2**, any test parameters left empty should always be set to "0".)
7. Set **parm_22** to the channel spacing, in MHz, which is the adjacent channel spacing for your receiver system.

8. Set parm_23 to “0” if you want to see the intermodulation products that fall exactly on the receive frequency or the adjacent channels.
 Set parm_23 to “1” if you want to see all calculated intermodulation products regardless if they fall on the receive frequency or not. The default setting for parm_23 is “1=Yes”.
9. Press **k5 (Main Menu)** (or **TESTS**) when you are done.

NOTE

The parameter settings you created should be saved into a procedure if desired. Refer to [Chapter 2](#), “Loading and Running the Software,” on [page 13](#). If you do not save the settings into a procedure, the information will reset to the defaults when you select a new procedure.

Running the Intermodulation Products Program

1. Select **k1 (Run Test)** to start the program. A display similar to figure 3-1 is displayed on the test set when parm_23 is set to “1=Yes”. In this case, all intermodulation products are displayed.

Figure 5-1 Sample Display of Intermodulation Products

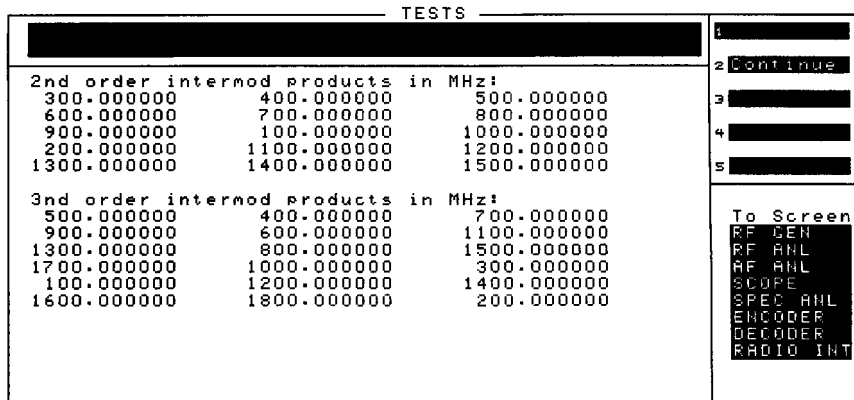

2. Select **k2 (Continue)** to display more intermodulation products. As each intermodulation calculation takes place, the test set displays on the top of the screen, the percentage of the measurement that is completed. Also, any TX frequencies and intermodulation frequencies within the channel spacing are printed out.
3. When the message **Intermodulation calculation complete** is displayed, press the **TESTS** key to exit the program.

6**SCANNER Library: Procedure,
Test, and Parameter Descriptions**

The SCANNER library contains the following tests:

- [TEST_01 SCANNER](#)

Procedures Pre-programmed in the SCANNER Library

The SCANNER library comes pre-programmed with two procedures:

- SCAN_DIS
- SCAN_SWP

SCAN_SWP runs a swept scan using values the user entered for start frequency, stop frequency and step frequency. SCAN_DIS runs a discrete scan of preprogrammed channels. To run these tests properly, the user should customize the **Channel Information (Edit Freq)** and **Parameter** table (**Edit Parm**) to enter the information specific to the test site. Remember to save the customized values to a new test procedure before changing the entry to the **Select Procedure Filename:** field. When the **Select Procedure Filename:** field is selected, the channel information and parameter values reset to the original default values if the new procedure was not saved. See [Chapter 2](#), “Loading and Running the Software,” on page 13 for information on how to save a test procedure.

Setting Up Discrete Scan Frequency Information

1. Press the **TESTS** key.
2. Select **Card** in the **Select Procedure Location: (or Location)** field.
3. Select the test procedure **SCAN_DIS**.
4. Select **FreqChannel Information** from the **CUSTOMIZE TEST PROCEDURE** list (or **Edit Freq** from the **Test Function** field).
5. Select the inverse-video box in the **Chan#** column. Turn the knob until the desired frequency (or position in the column) you want is highlighted in an inverse-video box, then push the knob to clear the cursor from the **Chan#** field.

6. Select the inverse-video field in the **Col A Freq** (left column) or **Col B Freq** (right column), depending upon which frequency you want to change. Key in the desired frequency in MHz.

Up to 100 frequencies can be entered into the program for scanning. **Col A Freq** is for frequencies 1A through 50A, and **Col B Freq** is for frequencies 1B through 50B.

The program uses the **TestA?** (or **Test?**) and **TestB?** (or **Prime?**) fields to determine if the frequencies listed in the right and left frequency columns are scanned. **TestA?** (or **Test?**) corresponds to the frequency in **Col A Freq** (left column), and **TestB?** (or **Prime?**) corresponds to the frequency in **Col B Freq** (right column). Selecting **Yes** in **TestA?** or **TestB?** causes the respective frequency in the same row to be scanned, and selecting **No** causes the respective frequency in the same row to be skipped.

The program scans frequencies sequentially from left to right, top to bottom. Frequencies set to 0.000 MHz are skipped. When a **Col A Freq** or **Col B Freq** is set to -1, the software stops scanning at that point and starts over at the beginning of the scan sequence.

7. Select the inverse-video field below the frequency you set in the previous step and enter a "label" to identify the frequency to be scanned.

The label field can also be used to select AM or FM demodulation. For example, If the label begins with "AM:", the AM demodulator will be used. If no label is entered, or if the label does not begin with AM: or FM:, the default demodulation will be FM except in the aircraft band and AM broadcast band.

Labels are optional, they are displayed with the received frequency when a channel is monitored by the frequency-scanning program.

8. Press **k5 (Main Menu)** (or **TESTS**) when you are done.

NOTE

The parameter and channel information (frequency) settings you created should be saved into a procedure if desired. Refer to [chapter 2](#) . If you do not save the settings into a procedure, the information will reset to the defaults when you select a new procedure.

Setting Up Swept Scan Frequency Information

- Press the **TESTS** key.
- Select **Card** in the **Select Procedure Location:** (or **Location:**) field.
- Select the test procedure **SCAN_SWP**.
- Select **FreqChannel Information** from the **CUSTOMIZE TEST PROCEDURE** list (or **Edit Freq** from the **Test Function** field).
- Select the inverse-video box in the **Chan#** column. Turn the knob until **Chan# 1** is highlighted in an inverse-video box, then push the knob to clear the cursor from the **Chan#** field.
- Select the inverse-video field in the **Col A Freq** (left column). Key in the desired Start Frequency.
- Select the inverse-video field in the **Col B Freq** (right column). Key in the desired Stop Frequency.
- Select the inverse-video box in the **Chan#** column. Turn the knob until **Chan# 2** is highlighted in an inverse-video box, then push the knob to clear the cursor from the **Chan#** field.
- Select the inverse-video field in the **Col A Freq** (left column). Key in the desired Step Frequency.
- Select the inverse-video field in the **Col B Freq** (right column). Key in the desired demodulation; FM: or AM:. (If no label is entered, or if the label does not begin with AM: or FM:, the default demodulation will be FM except in the aircraft band and AM broadcast band.)
- Press k5 (**Main Menu**) (or **TESTS**) when you are done.

NOTE

The parameter and channel information (frequency) settings you created should be saved into a procedure if desired. Refer to [chapter 2](#) . If you do not save the settings into a procedure, the information will reset to the defaults when you select a new procedure.

Test Descriptions

TEST_01 SCANNER

This test is used to scan either discrete or swept frequencies, depending on the values entered in the channel information table.

Running the Scanner

1. Connect an antenna to the test set's ANT IN connector.
2. Test frequencies and parameters must be correctly set for the program before you proceed. (See the previous sections).
3. Run TEST_01 SCANNER.
4. Adjust the **VOLUME** and **SQUELCH** controls on the test set to the desired levels for monitoring.
5. While the program is scanning for a signal, you can choose to stop the scanning (select **Stop Scan**) or you can step through the frequencies one at a time (select **Sngl Step**).
6. When the program is monitoring a signal, you can, in addition to stopping and stepping through the frequencies, choose to remove the monitored signal (select **Remove It**) and then continue scanning (select **Cont Scan**).

Measurements cannot be made to the monitored signal while the frequency-scanning program is running.

7. Press the **CANCEL** key when you want to exit the program.

Parameters Used

- [Parm_01 Receiver dwell time \(seconds\)](#)
- [Parm_02 Wide IF bandwidth \[0=no 1=yes\]](#)

Parameter Descriptions

Parameters are used to define the conditions under which a test will run. You may edit the parameters to change the default values, to meet your specific testing needs and conditions. Parameters may be used in one or more tests.

For information on editing parameters, see [“Customizing Testing”](#) on page 20.

Parm_01 Receiver dwell time (seconds)

Enter how long, in seconds, the test set will dwell at a received frequency once the signal disappears.

Parm_02 Wide IF bandwidth [0=no 1=yes]

Enter 0=**no** for selecting the narrow IF bandwidth (15 kHz in the HP 8920A,B; 30 kHz in the HP 8921A) or, 1=**yes** for selecting the wide IF bandwidth of 230 kHz.

The wide IF bandwidth should be selected when scanning transmissions with bandwidths greater than 25 kHz (for example, those in the FM broadcast band).

7

Save/Recall Register Utility (SAVRCL)

The SAVRCL procedure allows you to save instrument settings in save/recall registers for future use. This allows you to retrieve entire instrument setups instead of having to re-enter the individual settings.

This utility is used to manipulate those save/recall registers.

Common uses of this utility include copying save/recall registers from one test set to another and backing up registers before a firmware upgrade on a test set (firmware upgrades erase all registers from the test set's memory).

This program provides the following operations:

- Catalog a memory card to see what files are on it (page 87).
- Purge files from the card (page 88).
- Copy the save/recall registers in the test set to a memory card (page 89).
- Copy save/recall registers from a memory card to a test set (page 91).
- Format a memory card (page 92).

CAUTION

Save/Recall registers save all test set settings that have been changed from the factory power-on defaults. This includes any settings that are used to access optional hardware features, such as a cellular adapter or optional audio filters.

If all of your test sets are equipped with the same hardware options and the same firmware revision, you can usually copy registers from one test set to another without problems.

However, if the hardware options and firmware revisions do not match, copying registers may cause the instrument to attempt to access hardware settings that are not available and will freeze test set operation (also called a “firmware assert”). In this case, its power must be cycled to clear the problem.

This procedure does not use any parameters, specifications, or other customizable settings.

Catalog the Memory Card

This function displays a list of any save/recall registers that have been saved on the inserted memory card.

CAUTION

Only save/recall registers are listed. Other files, such as procedure files, may exist on the memory card that are not displayed when this function is used.

Use the following procedure to display a list of all save/recall registers on a memory card:

1. Load and run the SAVRCL procedure (see page 18).
2. Insert the memory card containing the save/recall registers.
3. Press the **k1** key, or position the cursor in front of the choice labeled “**k1: Catalog memory Card**” and then press the knob.
4. Press **k1 (Proceed)** to return to the previous menu.

Purge Files from the Memory Card

This function purges (deletes) any type of file from a memory card. You can remove a single file or all files from the memory card. This operation is helpful when you want to free up memory space by deleting unnecessary files.

CAUTION

This function removes *any* type of file, including any procedure files you may have saved. Procedure files can be identified by the lower-case “p” preceding the file for the HP 8920A, 21A, or followed by “.prc” for the HP 8920B.

Use the following procedure to purge files from a memory card:

1. Load and run the SAVRCL procedure (see page 18).
2. Insert the memory card containing the file(s) you want to purge.
3. Press the **k2** key, or position the cursor in front of the choice labeled “**k2: Purge Files from Memory Card**” and then press the knob. The screen shown in Figure 7-1 is displayed.

Figure 7-1 Purging Files From a Memory Card

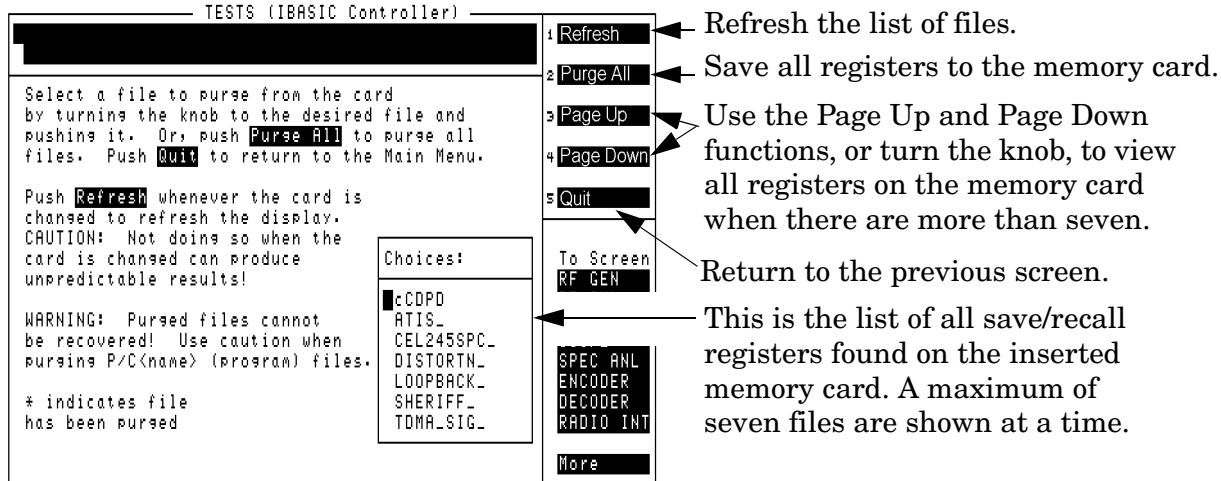

4. Use the knob to position the cursor in front of the file you want to purge, then press the knob to purge the file. You can also press **k2 (Purge All)** to delete all files on the card.

An asterisk (*) appears next to files that have been deleted. To view the current contents, press **k1 (Refresh)**.

5. Press **k5 (Quit)** when you are finished purging files.

Saving Registers to a Memory Card

Saving save/recall registers to a formatted memory card provides a way to copy registers to other test sets. (See page 92 for information on formatting the card.) It also allows you to restore the registers in a test set that has had a firmware upgrade or has had its memory assembly replaced. It may also be helpful when you need to run a program that uses most of the test set's RAM memory, requiring you to remove the save/recall registers that occupy memory space in the test set.

Saving a register to a memory card does not remove the original register from the test set it is copied from.

CAUTION

The test lets you save registers with names of up to nine characters in length. However, *memory card* file names can only be seven characters long. When copying registers with names of more than seven characters to a memory card, the test set shortens the name to seven characters by cutting off the last characters. When saving registers in the test set, you should try to use names of seven characters or less.

Also, any register names that were saved in the test set using lower case letters (through programs) will be copied to the memory card using all upper case letters.

Although the test set lets you save registers using the underscore character (`_`), do not save registers using the underscore for the first character (such as `_ce1123`). The SAVRCL program creates its own unique file for each saved register using the underscore at the start of the name to identify instrument settings. Creating your own files using the underscore at the start could prevent the register from being successfully copied.

Use the following procedure to save registers to a memory card:

1. Load and run the SAVRCL procedure (see page 18).
2. Insert a formatted SRAM memory card into the test set.
3. Press the **k3** key, or position the cursor in front of the choice labeled **"k3: Save Registers to Memory Card"** and then press the knob. The screen shown in [Figure 7-2 on page 90](#) is displayed.

Figure 7-2 Saving Registers to a Memory Card

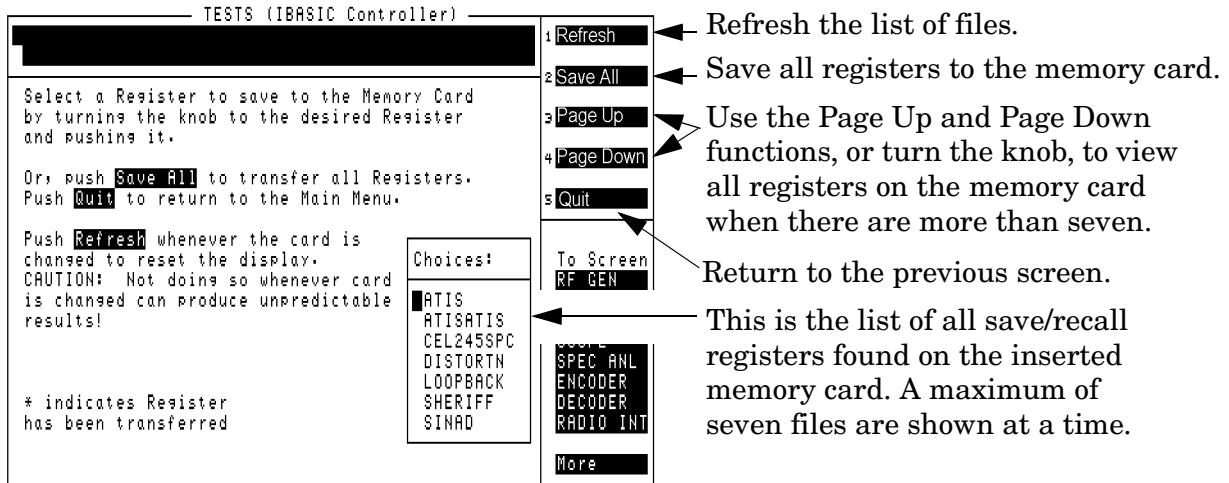

4. Use the knob to position the cursor in front of the register you want to save, then press the knob to save it. You can also select **k2 (Save All)** to save all registers in the test set to the card.
5. Press **k5 (Quit)** to return to the previous menu.

Restoring (Copying) Registers to the Test Set

This function copies save/recall registers from a memory card into the RAM of a test set. This lets you copy registers saved from one test set to another test set, or restore registers on a test set where the registers had been purged (such as after a firmware upgrade).

The original register on the memory card is not affected.

Use the following procedure to copy registers from a memory card into a test set:

1. Load and run the SAVRCL procedure (see page 18).
2. Insert the memory card containing the save/recall registers into the test set.
3. Press the **k4** key, or position the cursor in front of the choice labeled “**k4: Restore Registers to Test Set**” and then press the knob. The screen shown in Figure 7-3 is displayed.

Figure 7-3 Copying Registers From a Memory Card to the Test Set

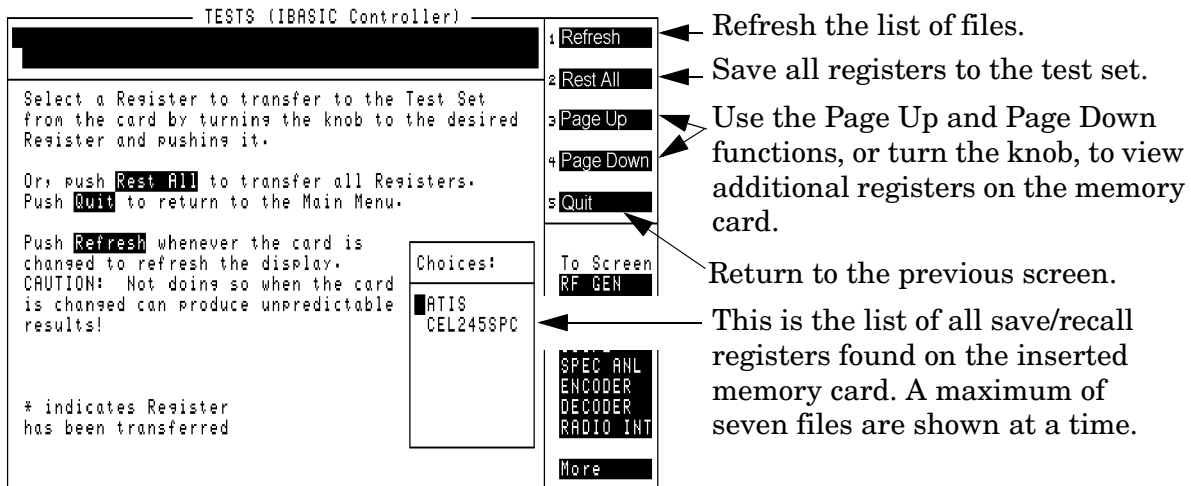

Formatting a Memory Card

A memory card must be formatted before data can be stored on it; much like a personal computer's hard or floppy disk. See "Memory Cards" on page 110.

CAUTION

Formatting the memory card erases any data stored on the card.

Use the following procedure to format a memory card:

1. Load and run the SAVRCL procedure (see page 18).
2. Verify that the write protect switch on the memory card you want to format is *not* set to "SAFE" or "WP".
3. Insert the memory card into the test set.
4. Select "--> Format Memory Card" and then press the knob. The screen shown in Figure 7-4 is displayed.

Figure 7-4 Formatting a Memory Card

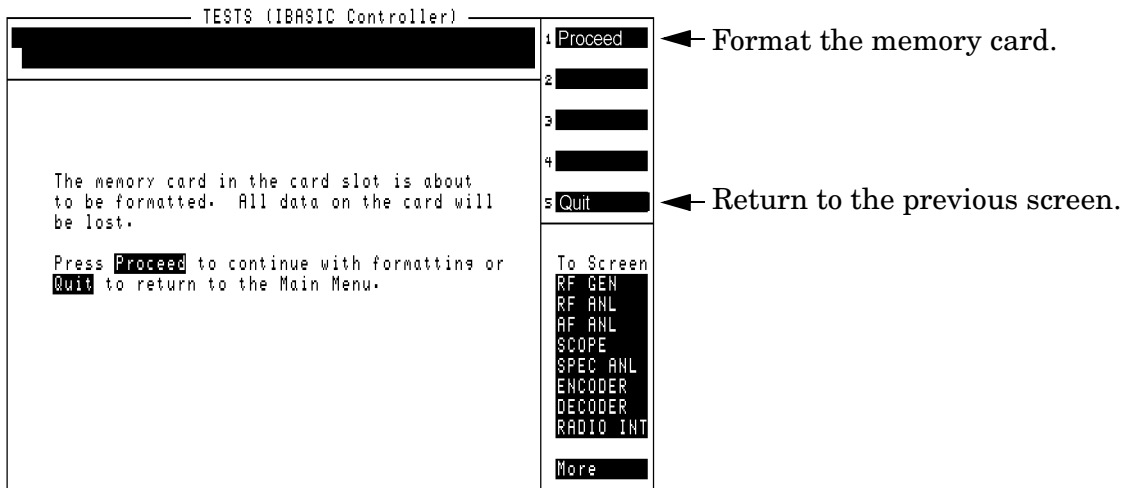

5. Press **k1 (Proceed)** to format the memory card. Do not interrupt the test set while the prompt "FORMATTING" is displayed.
6. Press **k1 (Proceed)** to return to the previous menu.

8 Reference (Alphabetical)

This chapter provides detailed descriptions of the features and functions of the HP 11807A,E software. Topics are arranged alphabetically on the pages indicated in the following list:

- “Conventions Used” on page 95
- “Copying Files” on page 96
- “Data Collection (Saving and Retrieving Test Results)” on page 97
- “HP-IB Control Annunciators” on page 109
- “Memory Cards” on page 110
- “Parameters” on page 115
- “Pass/Fail Limits (specifications)” on page 116
- “Pausing or Stopping a TEST” on page 117
- “Printing” on page 118
- “Procedures” on page 125
- “RAM” on page 131
- “Saving Tests Results” on page 134
- “Test Execution Conditions” on page 135
- “USER Keys” on page 137

Conventions Used

Special presentations of text in this manual reflect the appearance of the item being referred to.

Examples of these special presentations are:

TESTS

A key on the test set.

Procedure:

Characters displayed on the CRT display.

k1 (Run Test)

A USER key, in the key column next to the CRT. Run Test is displayed on the CRT.

0.000000

A field on the CRT where entries can be made.

Titles of documentation are printed in italics.

The term “test set” refers to the HP 8920A,B,D, 8921A,D.

In the steps in this manual the following words are used to describe cursor and entry actions:

- **select** refers to pressing the knob after positioning the cursor in front of the appropriate field (**inverse video** area).
- **choose** means to position the cursor in front of an item in the **Choices:** or **To Screen** menu in the lower right corner of the CRT display, and then press the knob.
- **enter** means to use the numeric keypad, and the ENTER key or measurement units keys to make entries to fields. In some procedures, *enter* is used to describe the action of entering characters into a field.

Copying Files

You can copy a file from a memory card to an SRAM memory card by loading the program from the memory card into the test set, inserting an initialized SRAM memory card, and then using the IBASIC SAVE command. Enter the following:

```
SAVE "MY_TEST:INTERNAL"
```

You can list the names of the files stored in a memory card catalog by using the IBASIC CAT command. To display a list of file names on a memory card, enter the following:

```
CAT ":INTERNAL" or CAT
```

The mass storage powers-up to memory card as a default. If you did not change this setting, then **" :INTERNAL"** is optional. If you are entering many characters into the IBASIC command line, you may want to connect a terminal to the test set. See ["Serial Connection" on page 119](#). You will also want to use a terminal if you have many files to list because file names displayed with the **CAT** IBASIC command scroll past the top of the test set's CRT display and cannot be scrolled down.

IBASIC is used when writing your own programs, and is not explained in this manual. See ["What is Not Explained in This Manual" on page 21](#) for a listing of programming manuals.

See also: ["Data Collection \(Saving and Retrieving Test Results\)" on page 97](#), ["Memory Cards" on page 110](#) and ["Formatting a Memory Card" on page 92](#).

Data Collection (Saving and Retrieving Test Results)

The software has the capability to save test results to an SRAM memory card or to a PC.

NOTE

The HP 11807A,E Option 100 software uses this function only with the RFTOOLS library.

Collection to a Memory Card

You will have to make entries into the External Devices (Edit Config) screen to describe the type of data collection you are using.

To configure External Devices entries:

1. Press the **TESTS** key.
2. Select **External Devices** from the **SET UP TEST SET** list (or **Edit Cnfg** from the **Test Function** field).
3. Position the cursor to the **Calling Name** field and select it.
4. Select **DATA COLLECTION** from the **Choices** menu to enter it into the **Calling Name** next to **Inst# 1**. The entry will look like:

```
1 DATA COLLECTION
```
5. Position cursor to the **Addr** field and select it.
6. Using the DATA keypad, enter a number into **Addr**, depending on the type of storage media you will be using (press ENTER when complete):

If you are using a memory card, enter **1** into the **Addr**:

```
1 DATA COLLECTION 1
```

Calling names can be entered in any order.

The test software supports data storage on Logical Interchange Format (LIF) and Disk Operating System (DOS) disk formats. Storage can be to any of the following file types:

- ASCII files under LIF
- BDAT files under LIF
- HP-UX files under LIF
- DOS files under DOS

You will be specifying the file type with the entry you make into the **Options** field immediately below **DATA COLLECTION**. If no file type is entered, and the disk format is LIF, the software will select an HP-UX file type. If no file type is entered, and the disk format is DOS, the software will select a DOS file type. For example, if you are using a DOS file and you are not using an extension on the file name, the entry on this screen will look like:

```
1  DATA COLLECTION      1
```

If you are using an ASCII, BDAT or HP-UX file, you can specify the number of records allocated to the file. The DOS file is automatically updated as data is stored, so record allocation is not required. If you are using HP-UX files, you will have to enter **REC=** to establish a usable number of records. **REC=20480** sets the size to be the same as the default number of 256 byte records used for ASCII files (80 x 256). You can enter the **REC=** after the file type. For example, to use an ASCII file with 200 records of 256 bytes each, you will enter **ASCII REC=200** into the **Options** field.

NOTE

For some software revisions, **REC=** and **ASCII REC=** will appear in the **Choices** menu. In this case, you may select **REC=** or **ASCII REC=**, enter the number of records using the **DATA** keypad, then select **Done**, instead of typing in each character individually.

The display will appear as follows:

```
1  DATA C      1
   ASCII REC=200
```

The default number of records, used when no **REC=** entry is made, is 80.

Items in the **Options** field can be separated by a comma or a space.

See “[Initializing an SRAM Memory Card](#)” on page 113 if using a new memory card. The file types under LIF can be used by the test set’s IBASIC controller and some HP workstations.

Table 8-1

Data Collection (Saving/Retrieving Tests) Configuration Summary

Inst#	Calling Name Options	Model	Addr	Description
1	DATA Collection	don't care	1	To memory card
Options: ¹	File types of ASCII, or BDAT, or (EXT), ² or blank, REC=xxxxx, (number of records)	don't care		LIF format DOS file type Number of Records
1	DATA Collection	don't care	9	Serial to external computer (laptop)

1. These options apply to memory card data collection. They do not apply when collecting data with Addr=9
2. A DOS file name extension. For example, the file name may be CELL1.EXT.

Retrieving Data from a Memory Card

To retrieve the test results after they have been saved on an SRAM memory card, see the “[Transfer Stored Data](#)” on page 56.

Collection to a PC

Test results can be output through the serial port. A variety of devices can receive the data. An HP Palmtop computer, PC, laptop, or terminal can be used. A terminal emulator can log the test results to a file. Examples of terminal emulator programs are HP AdvanceLink and ProComm, a product of DataStorm Technologies, Inc.

For example: Configuring an IBM-Compatible PC with HP AdvanceLink for DOS

1. Load and run HP AdvanceLink on your PC.
2. Use the following tables to set the *Global Configuration*, *Terminal Configuration*, and *Remote Configuration* settings.

Table 8-2 Global Configuration Settings

FIELD	SETTING
Keyboard	USASCII
Personality	HP
Language	English
Terminal Mode	Alphanumeric
Remote to	enter PC's serial port #
Printer I/F	None
Memory Size	32K
Plotter I/F	None
HP Mode	Yes
Video Type	Select your display type
Forms Path	Enter path if used
Screen Size	Enter the size

Table 8-3 Terminal Configuration Settings

FIELD	SETTING	FIELD	SETTING
Terminal ID	2392A	Esc Xfer(N)	YES
Local Echo	OFF	ASCII 8 Bits	YES
CapsLock	OFF	FldSeparator	US
Start Col	01	BlkTerminator	RS
Bell	ON	ReturnDef	CR
XmitFnctn(A)	NO	Copy	Fields
SPOW(B)	NO	Type Ahead	NO
InhEolWrp(C)	NO	ROW Size	80
Line/Page(D)	LINE	Host Prmpt Char	D1
InhHndShk(G)	NO	Horiz. Scroll. Incr.	08
Inh DC2(H)	NO	Large [+] Key	+

Table 8-4

Remote Configuration Settings

FIELD	SETTING	FIELD	SETTING
Baud Rate	4800	SR(CH)	LO
Parity/Data Bits	None/8	Recv Pace	None
Eng Ack	No	Xmit Pace	None
Asterisk	OFF	CS(CB)Xmit	NO
Chk Parity	NO		

The remote configuration settings must match the settings on the test set's I/O Configuration screen.

To set up for data collection to a PC:

1. Press the **TESTS** key.
2. Select **External Devices** from the **SET UP TEST SET** list (or **Edit Cnfg** from the **Test Function** field).
3. Position the cursor to the **Calling Name** field and select it.
4. Select **DATA COLLECTION** from the **Choices:** menu (next to **Inst# 1**):

```
1  DATA COLLECTION
```

5. Position the cursor to the **Addr** field and select it.
6. Using **DATA** keypad, enter **9** and press **ENTER**:

```
1  DATA COLLECTION      9
```

Calling names can be entered in any order.

Configuration for Terminal or PC Operation

To simplify entering data or IBASIC commands, you can connect a PC (operating with a terminal emulator program) to your test set.

1. Connect a cable between your PC serial port and the test set serial 9 port. [Figure 8-1 on page 104](#) shows a pin-to-pin wiring diagram for connecting your terminal to the test set serial 9 port.
2. Match your PC serial port and the test set serial 9 port communication settings (which are located on the **I/O CONFIGURE** screen).
 - a. Press the **TESTS** key.
 - b. From the **To Screen** menu, select **More**.
 - c. From the menu, select **IO CONFIG**. A screen similar to [Figure 8-2 on page 105](#) should be displayed.
 - d. In the second column of this screen, set the following fields as described below:
 - i. **Serial In: Inst**
 - ii. **IBASIC Echo: On**
 - iii. **Inst Echo: ON**
 - e. Set the fields in the third column to match the serial port settings of your PC. It is recommended that you set both the serial port settings of your PC and the test set to match the settings in [Figure 8-2 on page 105](#). Consult your PC terminal emulator program manual on how to configure you PC serial ports.

Figure 8-1 Test Set Serial 9 Port Wiring

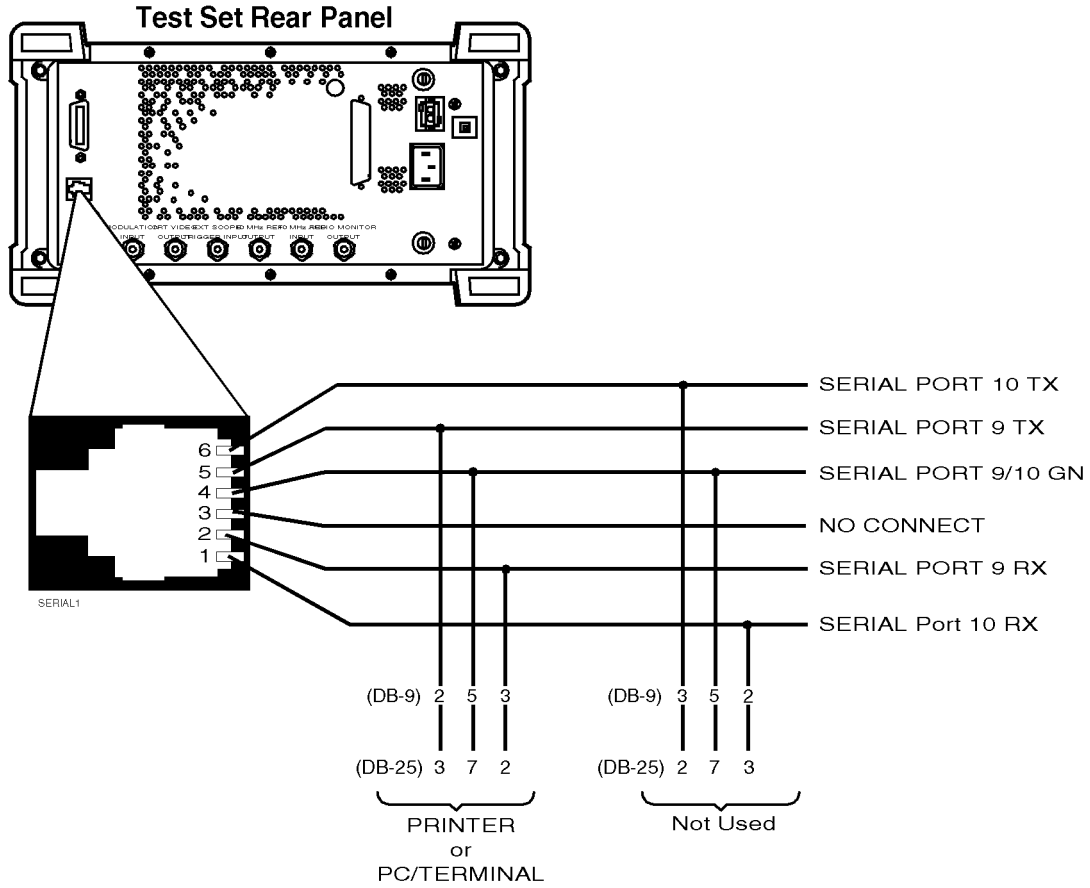
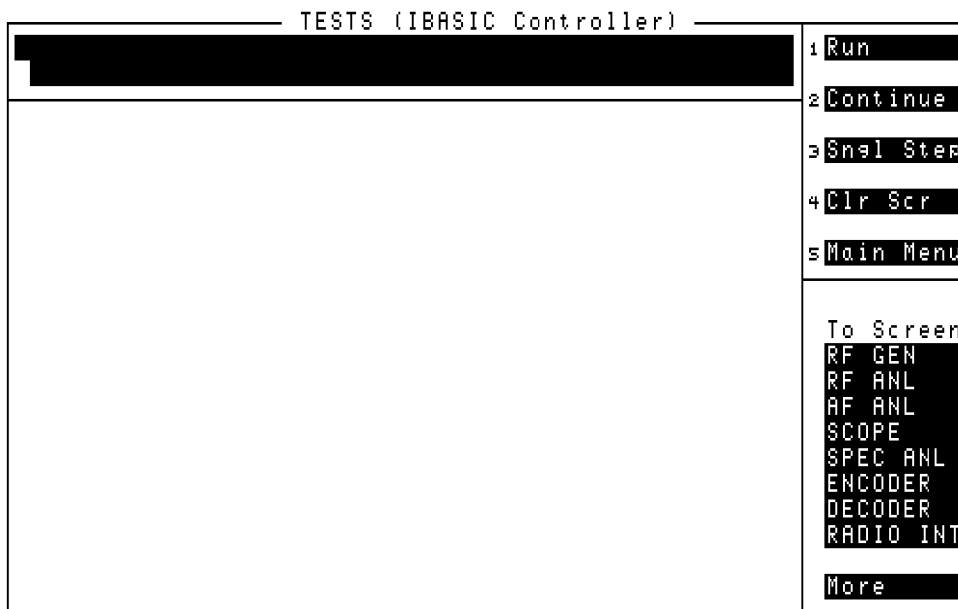

Figure 8-2 IO Configuration Screen

I/O CONFIGURE			
HP-IB Adrs 14	Serial In Inst/IBASIC	Serial Baud 9600	
Mode Talk&Lstn	IBASIC Echo On/Off	Parity None	
	Inst Echo On/Off	Data Length 8 bits	
		Stop Length 1 bit	
Save/Recall Internal		Rcv Pace None	
		Xmt Pace None	
			To Screen RF GEN RF ANL AF ANL SCOPE SPEC ANL ENCODER DECODER RADIO INT More

Verification that the Terminal Operation is Functional

1. Press the **TESTS** key.
2. Select **IBASIC Cntrl** from the **SET UP TEST SET** list (or **IBASIC** from the **Test Function''** field).
3. Position the cursor to the inverse video bar at the top of the screen as shown in [Figure 8-3](#).
4. Insert a memory card into your test set **Memory Card** slot.
5. From your PC terminal emulator program, type **CAT**. The test set should display a catalog of the memory card contents to both the test screen and you PC terminal emulator screen.

Figure 8-3 IBASIC Control Screen

If you find that you cannot enter IBASIC commands after an HP 11807A,E software package has run, check the I/O CONFIGURE screen to see if it has been modified. The software in many HP 11807A,E packages modify the serial 9 port settings during operation. Some software packages store the initial serial 9 port settings and return these settings when data entry is required. For these software packages, the data can be entered from your PC while the software is running.

Equivalent Front-Panel Control Characters

Your terminal emulator program sends special ASCII characters when you press function keys on your keyboard (for example: ENTER, CANCEL, BACKSPACE). These special ASCII characters may not be compatible with the commands for your test set, and may not produce the desired effect. Many of the front panel controls can be activated from your PC terminal emulator if the correct special ASCII characters are sent. Most terminal emulator programs provide function keys for customizing the keyboard. Consult your terminal emulator program user manual for information about creating a custom keyboard.

The following table lists the terminal/computer keystrokes that equate to the front-panel controls of the test set. *Each equivalent character must be preceded by the Escape key.*

For example, to remotely access the CONFIGURE screen, you type Esc, C on your terminal/computer. (Be sure to use upper-case C for this example.)

Alternate sequences for 5 commonly-used functions are also available. Hold down the Ctrl (control) key and select the corresponding key for the desired function. (Example: Ctrl/H moves the cursor to the left one space.)

ENTER - ^J or ^M

CANCEL - ^C

BACKSPACE - ^H

KNOB_TURN_CW - ^R

KNOB_TURN_CCW - ^L

Table 8-5 Equivalent Front-Panel Control Characters

Function	Equiv. ESC Char.	Function	Equiv ESC Char.	Function	Equiv. ESC Char.
CANCEL	!	SAVE	G	PRESET	i
PERCENT MHZ_V	(REF_SET	J	INCR_DIV_10	j
S_KHZ_MV)	METER	K	INCR_SEET	k
BACKSPACE	-	AVG	L	INCR_TIMES_10	l
ENTER	.	LO_LIMIT	M	DOWN	m
RELEASE	0	HI_LIMIT	N	UP	n
k1	1	E	R	SEVEN	o
k2	2	F	S	EIGHT	p
k3	3	B	U	NINE	q
k4	4	C	V	FOUR	r
k5	5	D	W	FIVE	s
k1_PRIME	6	A	X	SIX	t
k2_PRIME	7	EEX	Z	ONE	u
k3_PRIME	8	YES_ON_OFF	[TWO	v
ASSIGN	9	NO_PPM_W]	THREE	w
KNOB_TURN_CCW	<	RX	a	ZERO	x
KNOB_TURN_CW	>	TX	b	POINT	y
MSSG	A	DUPLEX	c	PLUS_MINUS	z
HELP	B	PREV	d	OHM_PCT_DEL_DBUV	{
CONFIG	C	TESTS_MAIN	e	DB_GHZ_DBM	
HOLD	D	LOCAL	f	MS_HZ_UV	}
PRINT	E	RECALL	g		
ADRS	F	MEAS_RESET	h		

HP-IB Control Annunciators

The words, letters, and symbols at the top right corner of the CRT display indicate these conditions:

- **R** indicates remote operation from an external controller or IBASIC program in the test set. This letter will be displayed while the software is running.
- **L** indicates that the test set is listening, and is ready to receive a manual or remote command.
- **T** indicates that the test set is talking to another HP-IB device.
- **S** indicates that a service request has been generated.
- **C** indicates that the test set is currently an active controller. Control mode is set on the I/O CONFIGURE screen. The test set must be a controller if HP-IB peripherals are to be controlled.
- ***** indicates that an IBASIC program is running, or that the IBASIC controller is executing a command.
- **?** indicates that an IBASIC program is waiting for a user response.
- **-** indicates that the IBASIC program is paused.
- **SHIFT** indicates that the **SHIFT** key was pressed, and that the next key entry will be shifted. (Press **SHIFT** again to clear).

Memory Cards

Memory cards are inserted into the slot on the test set's front panel. The memory card is powered by the test set while it is inserted. Arrows printed on the memory card and the test set's front panel indicate the direction and orientation of card insertion.

Memory cards are used to store or retrieve the following:

- Software code
- An HP-supplied Procedure, containing:
 - A default TEST sequence
 - Default test parameter values
 - Default pass/fail limit values
- A Library file
- Procedures you make, optimized for your application
- Data collection files
- Channel Information

Two types of memory cards are available:

- Static Random Access Memory (SRAM)
 - SRAM cards have read and write capability. SRAM cards can be programmed and read with the test set.
- One-Time Programmable (OTP)
 - Once programmed with a suitable card programmer, OTP cards have read-only capability. OTP cards can be read with the test set, but cannot be programmed with the test set.

The software memory card can be removed after the program is loaded into the test set memory. The program will remain in memory after a power-down/power-up cycle, until a new program is loaded. Loading a new program will replace the existing program.

SRAM Memory Cards

A Static Random Access Memory (SRAM) Card can be used to store test results and procedures you make. The following parts can be used.

Table 8-6 SRAM Memory Card Products for HP 8920/21A,D

Memory	Product
32 kilobytes	HP 85700A
128 kilobytes	HP85702A
256 kilobytes	HP 85704A
512 kilobytes	HP 85705A

NOTE

SRAM Memory Card Battery Life. The Static Random Access memory cards use a battery to retain data while the card is not plugged into a powered-up test set. The lifetime of the battery depends on the memory card size and the average temperature in its environment. See the next paragraph.

Current SRAM memory cards use a replaceable lithium battery (For HP 11807A: part number CR 2016 or HP part number 1420-0383). Programs and data will be retained for over one year if the memory card is stored at 25°C. The memory card is powered by the test set while it is inserted. Replace the battery while the memory card is inserted into a powered-up test set. To retain data and programs, it should be replaced annually. See the *HP 8920 or HP 8921A User's Guide*. If equipped, the write-protect switch on an SRAM memory card will write protect the card when it is set toward the outside of the card.

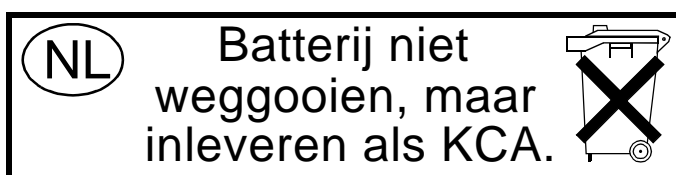

Memory Card Storage Space

Procedures use 12 to 16 records each. A Library uses 20 to 35 records. A single library must be included on the card. A record is 256 bytes. Approximately 11 kilobytes of overhead is required on each card.

Use the following formula to estimate the storage space needed:

$$\text{Storage Space (in kilobytes)} = (\text{Number of Procedures} \times 4.1) + 20$$

For example, if you want to save ten different procedures, you will need 61 kilobytes of memory. The 64 kilobyte or 128 kilobyte card is sufficient.

The storage space you need for data collection depends on the number of test results that are saved. You will need approximately 4 kilobytes per page of test results that you save. A page of test results is about 57 lines of CRT or printer output.

The storage space of smaller SRAM cards can be quickly used. If you are collecting large quantities of data, data collection using a PC or printer may be preferable.

Initializing an SRAM Memory Card

You can initialize a SRAM memory card several ways.

Initialize an SRAM Memory Card Using the SAVRCL Procedure

The HP 11807A,E Software contains a procedure called SAVRCL. One of the functions of this procedure is to format (initialize) memory cards. See [“Formatting a Memory Card” on page 92](#).

Initialize an SRAM Memory Card Using the Save/Delete Procedure Screen

Initializing HP 11807A cards (Smart Cards) using the TESTS Save/Delete Procedure screen automatically defaults to LIF format.

- Press the **TESTS** key.
- Select **Save/Delete Procedure** from the **CUSTOMIZE TEST PROCEDURE** list.
- Insert the SRAM card in the slot on the front panel. (Make sure the switch on the card is not in the write-protected position).
- Press **k3 (Init Card)**.
- Press **Yes** if you want to continue.

Initialize an SRAM Memory Card Using IBASIC

1. Press the **TESTS** key.
2. Select **IBASIC Cntrl** from the **SET UP TEST SET** list (or **IBASIC** from the **Test Function** field).
3. Position the cursor to the IBASIC command line and select it.
4. Using the list of characters under the **Choices** menu, enter the following IBASIC command:

For LIF format: **INITIALIZE “:INTERNAL”**

For DOS format: **INITIALIZE “DOS:INTERNAL”**

To initialize an SRAM memory card using RAM_MNG

1. Press the **TESTS** key.
2. Position the cursor to the **Select Procedure Location** (or **Location**) field and select it.
3. From the **Choices** menu, select **ROM**.
4. Position the cursor to the **Select Procedure Filename** (or **Procedure**) field and select it.
5. From the
menu, select **ChoicesIB_UTIL** (or **RAM_MNG**).
6. Press **k1 (Run Test)**.
7. Follow the displayed instructions.

NOTE

Loading RAM_MNG will delete any procedure or program in memory.

Retrieving Data from a Memory Card

To retrieve the test results after they have been saved on an SRAM memory card, see the test description in [“Transfer Stored Data” on page 56](#).

Parameters

Parameters are values you enter that optimize your use of the test software. Many of the parameters are determined by examining your test needs.

Default values are set into the software. Some of these values are derived from standard methods of measurement and some are derived from the industry standard requirements. Load a Procedure and select the Test Parameters screen from the **CUSTOMIZE TEST PROCEDURE** list, to see the default values.

You should verify that parameters are properly set after you select the tests to be placed in your procedure.

Parameters remain in battery-backed-up memory until you select a procedure to run. If you wish to prevent them from being lost when a new procedure is selected, you will have to save them in a procedure. See [“Saving a Procedure” on page 126](#).

To print the parameters list, see [“To print TESTS screens:” on page 124](#).

To edit a parameter value:

1. Press the **TESTS** key.
2. Select **Test Parameters** from the **CUSTOMIZE TEST PROCEDURE** list (or **Edit Parm** from the **Test Function** field).
3. Position the cursor to the **Parm#** field and select it.
4. Rotate the knob to the desired parameter number and select it.
5. Position the cursor to the **Value** field and select it.
6. Enter the desired value using the DATA keypad and press ENTER.
 - Use the ← key to backspace.
 - Press CANCEL to cancel entries and retain the old value.
7. Press **k5 (Main Menu)** (or **TESTS**) to return to the TESTS screen.

Pass/Fail Limits (specifications)

HP 11807A,E Option 100 software does not use the pass/fail limit (Edit Specification) function. If you try to select this screen, you will get the following message: **Access to secured test information denied.**

Pausing or Stopping a TEST

To pause the program, press CANCEL.

To stop the program, press **SHIFT** then **CANCEL**. This performs an IBASIC RESET operation.

NOTE

Changing Settings While Paused

If you make changes to instrument settings while the program is paused, subsequent operation may be unpredictable. Error messages may or may not be displayed. See Exiting a Program in this chapter.

To continue a paused program:

1. Press **TESTS**.
2. Press **k1 (Continue)**

The test time is displayed when the test is completed. This time includes the time that the program is paused and the time that it is waiting for connection and inputs to be made. If you are testing through midnight, the test time will not display properly.

Printing

You can print any of the following:

- Test results
- TESTS screens
 - "External Devices" (Edit Cnfg)
 - "Order of Tests" (Edit Seqn)
 - "Channel Information" (Edit Freq); FIELD_S and SCANNER libraries only
 - "Test Parameters" (Edit Parm)

How to Print (task list)

There are five basic steps to printing listed below. A detailed description of each of these steps is at the end of this section.

1. Check to see if your printer is supported by the test set (see ["Supported Printers" on page 118](#)).
2. Determine if your printer requires serial, parallel, or HP-IB connection. Connect the printer to the appropriate port on the test set (see ["Printer Connection" on page 119](#)).
3. Configure the test set for your printer and its interface (see ["Configuring the Test Set for Printing" on page 120](#)).
4. Instruct the test set what to print (see ["To print test results:" on page 121](#)).

Supported Printers

- HP ThinkJet printer
- HP QuietJet printer
- HP PaintJet printer
- HP DeskJet printer
- HP LaserJet printer
- Epson FX-80 printer
- Epson LQ-850 printer

If you do not have one of these printers, consult your printer's manual for the correct printer settings to emulate one of the supported printers.

Printer Connection

HP-IB Connection

An HP-IB printer can be connected to the test set's rear-panel HP-IB connector with an HP-IB cable.

Serial Connection

A serial printer can be attached to the serial port. See [Figure 8-4](#). Use the following RJ-11 pins for this connection.

- RJ-11 Pin 2 - test set Receive Data
- RJ-11 Pin 4 - Ground
- RJ-11 Pin 5 - test set Transmit Data

Figure 8-4 Test Set RJ-11 Serial Port Connections

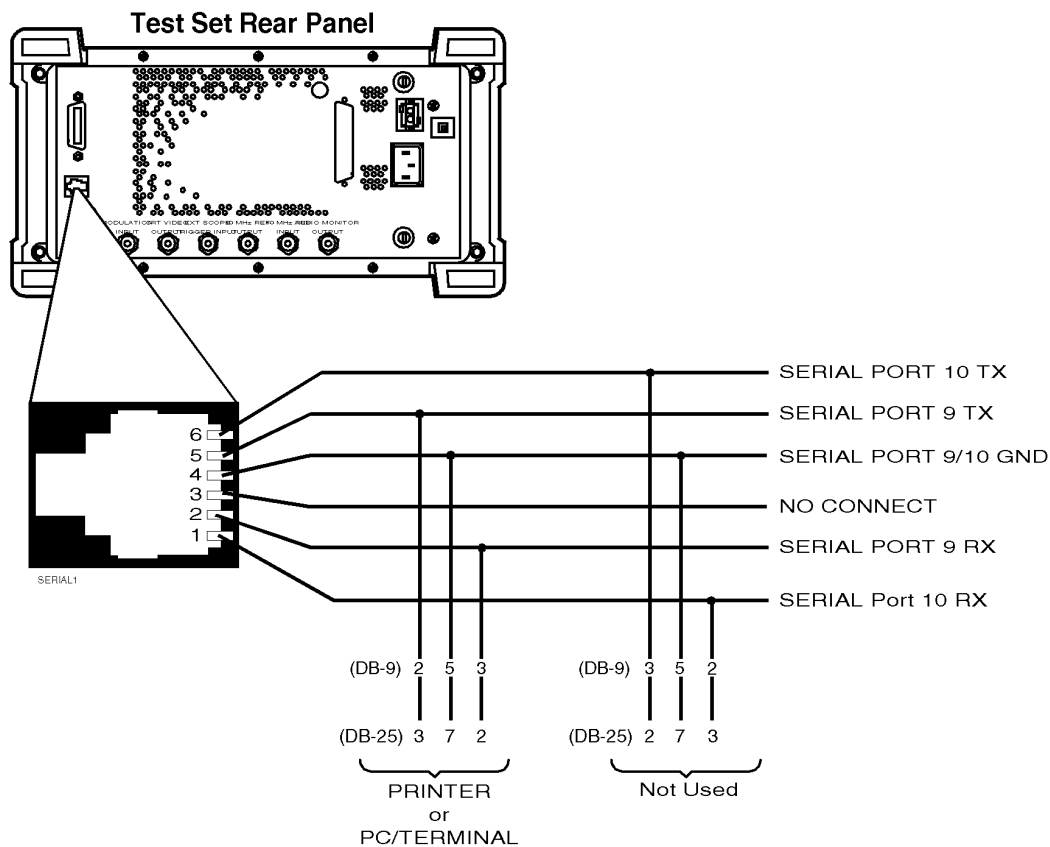

Parallel Connection

A parallel printer can be attached to the parallel port. Use the following [Figure 8-5](#) for pin information.

Figure 8-5 Test Set Parallel Port Connections

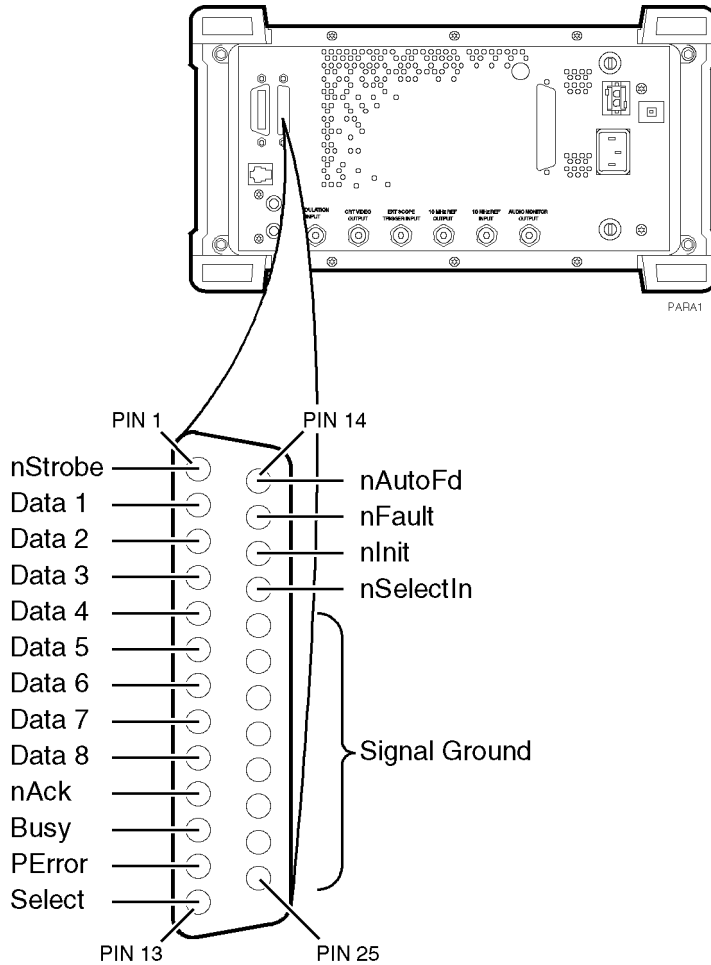

Configuring the Test Set for Printing

If using a serial printer, you cannot use the serial port for other connections at the same time, such as data collection (saving test results). Serial port connections are shown earlier in this section.

To Setup a Printer

1. Press the **TESTS** key.
2. Select **Printer Setup** from the **SET UP TEST SET** list.
3. Position the cursor to **Model** and select the desired printer.
4. Position the cursor to **Print Port** and select the desired port.
5. (If HP-IB only) Position the cursor to **Printer Adrs** and enter the HP-IB address for your printer (0-30).
6. Set the following options if desired:
 - a. **Lines/Page** (controls the number of lines, 20 to 120, printed on a page before a form feed is sent to the printer)
 - b. **FF at Start** (to cause a form feed at the start of a test sequence)
 - c. **FF at End** (to cause a form feed at the end of a test sequence)
7. From the **To Screen** menu, select **More**.
8. From the **Choices** menu, select **IO CONFIG**.
 - a. For Serial Printing, set the **Serial Baud** field and other serial communications fields listed under it to correspond to your printer's configuration.
 - b. For HP-IB Printing, set the **Mode** field to **Control**.
9. Press **TESTS** to return to the TESTS (Main Menu) screen.

To print test results:

1. Press the **TESTS** key.
2. Select **Printer Setup** from the **SET UP TEST SET** list.
3. Position the cursor to **Output Results To** and select **Printer**.
4. Position the cursor to
and select **Output Results ForAll** if you want all results printed,
or **Failures** if you want failures only printed.
5. (Optional) Position the cursor to **Output Heading** and enter your desired heading.

To send Escape Sequences to the printer

If you have revision B.xx.xx software, you may use the test set to send escape sequences to control printer options such as pitch, margins, paper size, and do forth. The software comes with some pre-defined escape sequences compatible with HP printers, listed below, or you have the option to enter others which are compatible with your printer (use your printer's user's manual for the available print features and corresponding escape sequences). This function is not available with revision A.xx.xx software.

The software already has an implied escape character for the first sequence, you need only to enter the escape sequence following the escape character. However, if you are linking two or more sequences together, you must use the ~ to indicate the escape character between each sequence. If the sequence exceeds the space allotted in the options field, you may continue with additional escape sequences in the next available **Options** field. You must however, still enter **Escape Seq** in the **Calling Name** field and the appropriate address in the **Addr** field for all subsequent entries.

How to send an Escape Sequence:

1. Press the **TESTS** key.
2. Select **External Devices** from the **SET UP TEST SET** list.
3. Position the cursor to the **Inst#** field and select it.
4. Rotate the knob until an empty **Calling Name** field appears, and select it.
5. Position the cursor to the **Calling Name** field and select it.
6. Select **Escape Seq** from the **Choices** menu.
7. Position the cursor to the **Addr** (address) field and select it.
8. Using the **DATA** keypad, enter **9** for serial printers, **15** for parallel printers, or **70x** for HP-IB printers, then press **ENTER**.
9. Position the cursor to the **Options** field (directly under **Calling Name**) and select it.
10. Select the desired escape sequence from the **Choices** menu if applicable, or enter an appropriate sequence using the list of characters below the choices.

Table 8-7 **Escape Sequence Definitions for HP Printers**

Escape Sequence	Print Feature
&l66P	Sets page length to 66 lines
&l72P	Sets page length to 72 lines
&l6D	Sets lines per inch to 6 lines
&l8D	Sets lines to inch to 8 lines
(s12h12v6T	Selects 12 characters per inch 12/72 inch character height gothic typeface
&a9L~&l6E	Sets left margin to 9 characters top margin to 6 lines
(s12h12v6T~&a9L~&l6E	Selects 12 characters per inch 12/72 inch character height gothic typeface left margin to 9 characters top margin to 6 lines
&l8d88P	Selects 8 lines per inch 88 lines per page
&l8d96P	Selects 8 lines per inch 96 lines per page
(s16.67h12V~&a17L~&l6E	Selects 16.67 characters per inch 12/72 inch character height left margin to 17 characters top margin to 6 lines

To print TESTS screens:

TESTS screens include:

- "External Devices"
- "Order of Tests"
- "Channel Information"; FIELD_S and SCANNER libraries only
- "Test Parameters"

The same general process is used to print the information for all of the above TESTS screens.

1. Make sure that your printer is properly connected and configured as explained earlier in this section.
2. Press the **TESTS** key.
3. Select the CUSTOMIZE TEST PROCEDURE screen of your choice.
4. Press **k3 (Print All)** and select it.
5. Press the **TESTS** key to return to the TESTS (Main Menu) screen.

Procedures

A procedure is a collection of test parameters and a testing order (and channel information in FIELD_S and SCANNER libraries), saved in a file that customizes the test software to a specific application. You may save the file on a memory card.

You do not have to save more than one test in a procedure. Each test can be stand-alone if desired. After you choose a procedure, you can choose which of the tests you want to run.

When you save a procedure you will only be saving test parameters and a testing order (and channel information for FIELD_S and SCANNER libraries). The memory card must also contain a library file. A library file contains all of the test parameters and tests that are associated with the current test software program. The HP 11807A,E Option 100 software card contains five libraries: RFTOOLS, FIELD_S, INTRMOD, SCANNER, and SAVRCL. Each library is associated with a separate software program, also contained on the software card. When you save your procedure, the current library will be automatically saved on the same card.

The procedure(s) supplied with your software will be listed in the **Choices:** column when you select the **Select Procedure Filename:** (or **Procedure**) field. Procedures will be displayed if your software memory card is plugged in.

Saving a Procedure

After you have set up the test software you can save the setup to an SRAM memory card or internal RAM memory by doing the following.

The memory card you use must be initialized before its first use. See [“Initializing an SRAM Memory Card” on page 113](#).

To save a procedure:

1. Press the **TESTS** key.
2. Select **Save/Delete Procedure** (from the **CUSTOMIZE TEST PROCEDURE** list).
3. Position the cursor to the **Select Procedure Location** field and select it.
4. From the **Choices** menu, select the desired location to save the procedure to. The media must be initialized before a file can be saved.

To initialize a SRAM card:

- a. Insert card in the slot on the test set’s front panel.
- b. Press **k3 (Init Card)**
- c. Press **Yes**. Note: this will delete any procedures or programs from memory.

To initialize a RAM disk, see [“Initializing RAM Disks” on page 132](#).

5. Position the cursor to the **Enter Procedure Filename** (or **Procedure**) field and select it.
6. From the list of characters in the **Choices** menu, enter a filename. Filename must be nine characters or less. When filename is complete, position cursor to **Done** and select it. Procedure filenames that already exist on the card will appear at the top of the list of characters.
7. If you selected **Card**, insert an initialized memory card into the slot on the test set’s front-panel.
8. Verify that the card or other media is not write-protected. See [“Memory Cards” on page 110](#).
9. Position the cursor to the **Enter Description for New Procedure** (or **Comment for new procedure**) field and select it. From the list of characters in the **Choices** menu, enter comments. When the comments are complete, position the cursor to **Done** and select it.
10. Position the cursor to the **Procedure Library** (or **Library for new procedure**) field and select **Current** (Current underlined). The name of the Library is displayed on the **TESTS** screen.

11. Position the cursor to the **Code Location** (or **Program location for new procedure**) field and select it.

From the **Choices** menu, choose memory **Card**, **ROM**, **RAM** or **Disk**. When a procedure is run, the test system will look in this location for a code file if it is not resident in the Test Set's battery-backed-up memory. This location will usually be the software memory card.

12. Press **k1** (**Save Proc**) (or position the cursor to the **Action** field and select **Make Procedure**). A procedure will be saved at the location you chose.

NOTE

If the filename already exists you will get a **Duplicate file name** error message. **If you would like to replace the existing file:**

- Position the cursor to the **Enter Procedure Filename:** field and select it.
 - Enter the filename you wish to replace.
 - Press **k2** (**Del Proc**). This will delete the original file. You will not lose the edits you made to the current procedure.
 - Press **k1** (**Save Proc**). This will save the current procedure to your desired filename.
-

Loading a Procedure

A procedure can be loaded from storage media into the test set's battery-backed-up memory by doing the following.

To load a procedure:

1. Press the **TESTS** key.
2. Position the cursor to the **Select Procedure Location** (or **Location**) field and select it.
3. From the **Choices** menu, choose the desired location where the procedure is stored and select: **Card, ROM, RAM** or **Disk**.
4. Position the cursor to the **Select Procedure Filename** (or **Procedure**) field and select it.
5. From the **Choices** menu, choose the procedure file that you want to load.
6. Read the **Description** (or **Comment**) field to ensure that the loaded procedure file is the one you want.

Deleting a Procedure

Procedures can be removed from an SRAM memory card, disk or RAM by doing the following.

To delete a Procedure:

1. Press the **TESTS** key.
2. Select **Save/Delete Procedure** from the **CUSTOMIZE TEST PROCEDURE** list (or **Proc Mngr** from the **Test Function** field).
3. Position the cursor to the **Select Procedure Location** (or **Location**) field and select it.
4. From the **Choices** menu, select the desired location.
5. Position the cursor to the **Enter Procedure Filename** (or **Procedure**) field and select it.
6. From the **Choices** menu, select the name of the procedure you wish to delete.
7. Press **k2 (Del Proc)** (or position the cursor to the **Action** field and select **Delete Procedure**).
8. Press the **Yes** key if you wish to continue.

Securing a Procedure

After you have set up your test software with a testing order, channel information, and test parameters, you may wish to secure it. This operation will prevent the viewing and changing of those functions. You can select the items you wish to secure or un-secure. An IBASIC ROM program is stored in the Test Set's firmware to do this.

You can secure the procedure that is supplied with the test software. It is shipped un-secured.

After you make a procedure, you can secure it.

To secure a Procedure:

1. Press the **TESTS** key.
2. Position the cursor to the **Select Procedure Location** (or **Location**) field and select it.
3. From the **Choices** menu, select **ROM**.
4. Position the cursor to the **Select Procedure Filename** (or **Procedure**) field and select it.
5. From the **Choices** menu, select **IB_UTIL** (or **SECURE_IT**).
6. Press **k1** (**Run Test**).
7. Select the location of the procedure you want to secure: **k1** (**Card**) or **k2** (**RAM**).

NOTE

RAM refers to the RAM Disk memory within the test set. Before selecting RAM, you must initialize the RAM as a disk. See [“Initializing RAM Disks” on page 132](#).

8. Proceed with the on-line instructions. You may wish to secure only one of the items, such as pass/fail limits.
9. When you are prompted to enter the **pass number**, enter any sequence of numerals 0 through 9 using the DATA keypad. Enter 9 digits or less.

To un-secure a procedure:

To un-secure a procedure, you must know the **pass number**.

1. Press the **TESTS** key.
2. Position the cursor to the **Select Procedure Location** (or **Location**) field and select it.
3. From the **Choices** menu, select **ROM**.
4. Position the cursor to the **Select Procedure Filename** (or **Procedure**) field and select it.
5. From the **Choices** menu, select **IB_UTIL** (or **SECURE_IT**).
6. Press **k1 (Run Test)**.
7. Select the location of the procedure you want to un-secure: **k1** memory (**Card**) or **k2 (RAM)**.
8. Enter the name of the procedure you wish to un-secure.
9. If the procedure has any item secured, you will be asked for the **pass number**.
10. Proceed with the on-line instructions. Select the items you wish to un-secure.
11. When you are prompted, enter the **pass number** using the **DATA** keypad.

RAM

RAM disk is a section of internal memory that acts much like a flexible disk. Programs can be stored, re-stored, erased, and retrieved.

The RAM disk is partitioned into four separate volumes; 0-3. Each volume is treated as a separate 'disk'. You can also specify the size of each disk in 256-byte increments.

The four RAM disk volumes are designated **:MEMORY,0,0** to **:MEMORY,0,3**. For example, to catalogue the contents of RAM disk volume '0' from the IBASIC Cntrl screen, enter

```
CAT ":MEMORY,0,0"
```

Volume 0's contents can be viewed.

NOTE

Ram Disk Erasure

Any existing programs or formatting on RAM is erased if you use the **RAM_MNG** or **COPY_PL** ROM programs, or the **SERVICE** screen's **RAM Initialize** function.

Therefore, you should only use RAM disks for short-term storage of files.

Initializing RAM Disks

Each RAM disk volume must be initialized before it can be used.

NOTE

If you are using a RAM disk to store a test procedure, you must initialize the RAM disk volume 0. When the software saves a procedure to the test set's RAM, it automatically stores the procedure into the memory location volume 0. This is not changeable.

To initialize RAM disk Volume 0:

Volume 0 can be initialized using the **RAM_MNG** procedure stored on the internal ROM's **IB_UTIL** menu.

1. Press the **TESTS** key.
2. Position the cursor to the **Select Procedure Location** field and select it.
3. From the list in the Choices menu, select **ROM**.
4. Position the cursor to the **Select Procedure Filename** field and select it.
5. From the list in the Choices menu, select **RAM_MNG**. **RAM_MNG** is the RAM manager program.
6. Press **k1 (Run Test)**. The program will begin execution.
7. Read the precautions provided on the test set's screen and then press **k1 (Yes)** to continue.
8. Press **k3 (Int RAM)**. This selects the test set's internal RAM as the location to be initialized.
9. Enter the number of records you wish to initialize using the data key pad and then press **ENTER**. 50 records should be sufficient for saving a procedure.
10. Press **k1 (Yes)** to verify the number of records was entered correctly. The internal RAM **:MEMORY,0,0** is initialized.

To initialize RAM volumes 1, 2, or 3:

1. Press the **TESTS** key.
2. Select **IBASIC Cntrl** from the **SET UP TEST SET** list.
3. Position the cursor to the data entry field and select it.
4. Using the list of characters from the **Choices** menu, enter the following command:

```
INITIALIZE ":MEMORY,0,<volume number 1-3>",<volume size>  
or  
INITIALIZE ":MEMORY,0,1",50
```

The optional “volume size” lets you specify the memory area set aside for each disk in 256 byte blocks.

Saving Tests Results

See “Data Collection (Saving and Retrieving Test Results)” on page 97.

Test Execution Conditions

In some situations, you may wish to change the way the software works when a test result is obtained. **Test Execution Conditions** allow you to do this.

Test Execution Conditions are accessed from the **SET UP TEST SET** list on the TESTS (Main Menu) screen. Press the **TESTS** key, then select **Execution Cond** to display them.

Test Execution Conditions are not retained after a power-down/power-up cycle.

The following **Test Execution Conditions** can be set as needed:

Output Results To: (Output Destination)

You can select either: **Crt** or **Printer** Default:**Crt**

You can specify where test results are to be placed. If you select **Crt**, results will be displayed on the test set's CRT. If you select **Printer**, test results will be sent to the CRT and to a printer. You must connect and configure a printer if you select **Printer**. See [“Printing” on page 118](#).

Output Results For: (Output Results)

You can select either: **All** or **Failures** Default:**All**

You can specify if you want only the failed results to be displayed or printed. This will be useful if you generally do not print test results, and want to ensure that failed results are displayed or printed.

Output Heading

You can use this field to enter a heading that will be printed or displayed.

Select the **Output Heading** field. Use the knob to choose and enter the characters that you want to appear in the heading. Choose **Done** when you are finished.

If Unit-Under-Test Fails (If UUT Fails)

You can select either: **Continue** or **Stop** Default: **Continue**

If you set this to **Stop**, and a pass/fail result is **F**, the program will stop.

Test Procedure Run Mode (Run Mode)

You can select either: **Continuous** or **Single Step** Default: **Continuous**

You can make tests pause at certain times. If you set this to **Single Step**, the program will pause after a comparison is made between a test determination and the expected result. For example, tests will pause after the program compares the results to a specification. You can continue from the paused state by pressing k2 (**Continue**).

Autostart Test Procedure on Power-Up

You can select either: **On** or **Off** Default: **Off**

You can set up the test set so that if the procedure was previously loaded, the procedure will be immediately executed when the test set is powered on.

USER Keys

When you are using the test set, you will see the following USER keys assigned appear at times in the top right corner of the display. These keys are assigned to the hard keys k1 through k5. In many cases, these keys can be used as “shortcuts” instead of positioning the cursor and selecting. USER keys are sometimes referred to as softkeys.

Clr Scr clears the test set’s CRT display.

Continue continues the program after it has been paused.

Delet Stp is used to edit items in a test sequence. When you press this key, the test in the displayed sequence that has its **Step #** highlighted (inverse video) will be deleted. The tests that follow in the sequence will be scrolled up by one step.

Del Proc is used to delete the selected procedure. When you press this key, you will be prompted to verify the command by pressing Yes.

Press **Done** when you want to exit a test or have completed a task. The program will continue if there is a next test in the sequence or if there are additional program steps in the test being run.

Help provides information on how to use the current TEST screen.

Init Card is used to initialize a memory card. Before you press this key, verify that the card is inserted correctly and not in the write-protected position.

Insrt Stp is used to enter items into a test sequence. When you press this key, the test in the displayed sequence that has its **Step #** highlighted (inverse video) will be copied into a new sequence location, immediately after the highlighted one. The tests that follow in the sequence will be scrolled down by one step. This key does nothing if there are no items in the sequence. Choose a test before using this key to insert another.

Main Menu is used to return to the main TESTS screen. The same result is achieved by pressing TESTS.

Run starts an IBASIC program that has been loaded into the test set’s memory.

Run Test loads and runs the program that is called from the procedure that has been entered into the TESTS screen **Select Procedure Filename:** entry. If the program is already loaded into the test set’s memory, it will be started.

Save Proc is used to save the specified procedure.

Reference (Alphabetical)
USER Keys

A **Appendix A: RFTOOLS Program Tutorial**

The RFTOOLS program in your HP 11807A,E Option 100 Rev B.00.03 software provides network analyzer type measurements from your test set. The program does this by properly configuring the internal spectrum analyzer (SA) for making measurements and then formatting the measurement data for display.

The internal spectrum analyzer performs an automatic self-calibration every 5 minutes. This automatic self-calibration insures that the spectrum analyzer operates within specified limits regardless of the operating temperature. This self-calibration can introduce instability in spectrum analyzer's output after the test set is operating at a constant temperature.

Each RFTOOLS test includes two parts: calibration and measurement. If the spectrum analyzer performs a self calibration between the calibration and measurement of the RFTOOLS test, the spectrum analyzer's automatic self-calibration instability will increase RFTOOLS test measurement error. To avoid this problem, the RFTOOLS test program includes a test (SA self calibration ON/OFF), to turn off the spectrum analyzer's self-calibration. This self-calibration should only be turned off after the unit has reached a constant powered-on operating temperature. When the self-calibration is off, the measurement accuracy and stability of RFTOOLS tests will improve.

Running the RFTOOLS Tests

Select the Procedure File

1. Turn on your test set and let it warm up for 30 minutes. This will stabilize the internal oscillator and allow the internal spectrum analyzer temperature to stabilize.
2. Insert your 11807A,E Option 100, Revision B.00.03 card in the MEMORY CARD slot.
3. Press the **TESTS** key.
4. Select **Card** in the **Select Procedure Location: (or Location:)** field.
5. Select **RFTOOLS** in the **Select Procedure Filename:** field. The screen should now look as shown in [Figure A-1](#).

Figure A-1 Selecting the RFTOOLS Procedure File

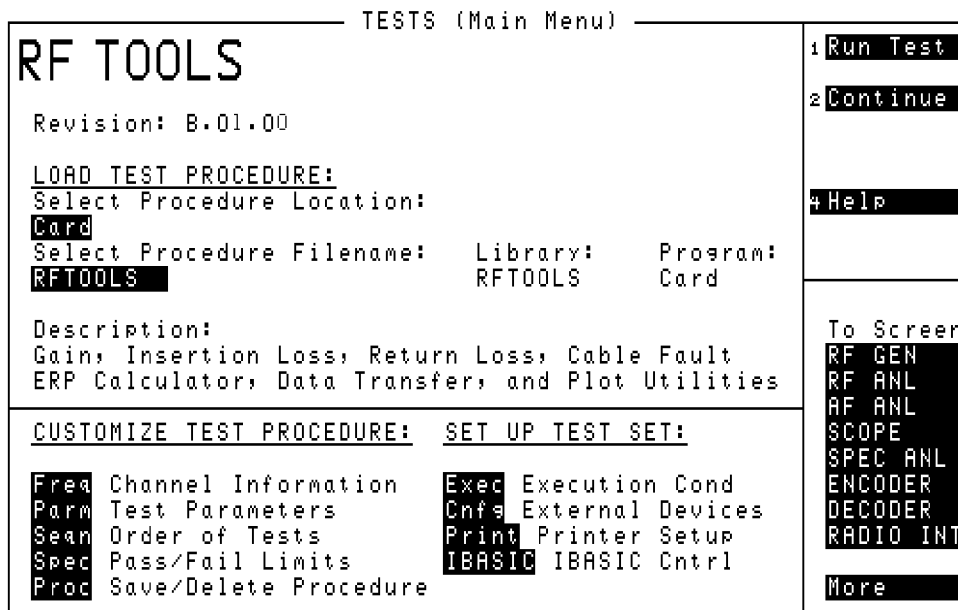

Customize the Parameters

View the Test Parameters

1. Select **Test Parameters** from the **CUSTOMIZE TEST PROCEDURE** list (or **Edit Parm** from the **Test Function** field).
2. Position the cursor to the **Parm#** field and select it.
3. You may now scroll through the list to view each parameter and its default setting.

Parameter Overview

- Parameters 1 through 21 are the default test parameters for each of the RFTOOLS tests. A subset of these will be presented to you at the beginning of each test for approval or modification. If you find that you always change those parameters to the same set of values prior to testing, you can change the default values here in the parameters lists, and save them in a new procedure file.
- **Parm_22** Use data collection labels [0=No 1=Yes] provides you with the option of labeling test data for each test and each test iteration.
- **Parm_23** Show all data files [0=No 1=Yes] determines which type of memory card files are show in the Transfer stored data test. When **parm_23** is set to 0=**no**, only data files are shown. When **parm_23** is set to 1=**yes**, all file types are shown.

Edit the Test Parameters

For this tutorial, change the setting for parameter 22.

1. Position the cursor to parm_22 Use data collection labels.
2. Using the DATA keypad, press 1 to change the setting from 0=No to 1=Yes.

This will allow you to label the collected data for later identification.

Run the RFTOOLS Test Procedure

1. Press the **TESTS** key.
2. Press **k1 (Run Test)**.
3. The RFTOOLS Select Test Menu will appear with a selection of all the tests available in the RFTOOLS library. See [Figure A-2](#).

Figure A-2 RFTOOLS Select Test Menu

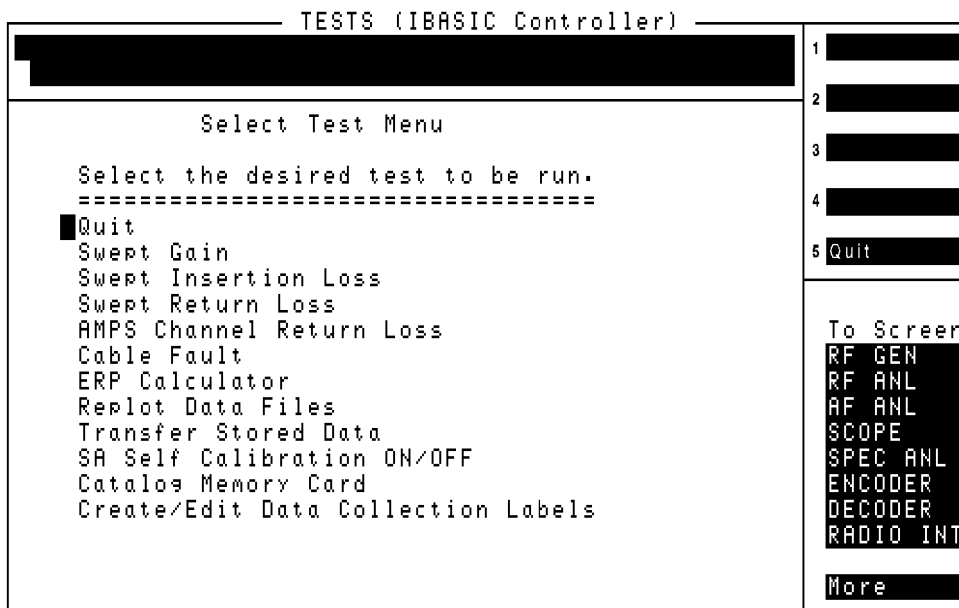

Test Overview

- *Swept Gain, Swept Insertion Loss, Swept Return Loss, AMPS Channel Return Loss, and Cable Fault* perform analyzer type measurements.
- *ERP Calculator* can calculate any transmit ERP based on the input power, antenna gain, and antenna feed cable loss.
- *Replot Data Files* is used to replot data stored on the memory card by the first five tests (mentioned above).
- *Transfer Stored Data* is used to transfer data collection files or plot file data to your PC.
- *SA Self Calibration ON/OFF* is used to check or change the status of the spectrum analyzer's self-calibration.
- *Catalog Memory Card* catalogs the memory card and displays the memory card contents on the screen.
- *Create/Edit Data Collection Labels* is a label making utility which allows you to create text labels to attach to measured data when printing or storing data to either your laptop computer or the internal memory card. (This test only appears in the **RFTOOLS Select Test Menu** if *parm_22 Use data collection labels [0=No 1=Yes]* is set to 1=Yes).

In this tutorial, you will run the *Swept Return Loss* and *Cable Fault* tests. These two tests are used to diagnose antenna problems.

Equipment Needed to Run Swept Return Loss and Cable Fault

- Reflection bridge
- Two (2) 6-dB attenuators
- Resistive power splitter
- Two sections of RG 223 or equivalent cable. (Check your base station cable kit for these cables.)

Build a List of Data Collection Labels

Before you begin testing, it is useful to build a list of data collection labels for data identification. Parm_22 Use data collection labels must be set to 1=Yes for the **Create/Edit Data Collection Labels** test to appear in the test menu.

For this example, assume you are in cell site 1, which is a three-sector site. Antennas are connected to faces 0, 1, and 2.

1. Position the cursor to the **Create/Edit Data Collection Labels** test and select it. (You should be on the RFTOOLS Select Test menu.)
2. The test menu shown in [Figure A-3 on page 146](#) will appear.
3. Position the cursor to **select label file name** and select it.
4. Press **1**, **ENTER**, to represent cell site 1.
5. Position the cursor to **Edit labels shown below** and select it. This will allow access to the label fields below the double line.
6. Position the cursor to line **L1** and select it.
7. Enter the label shown in [Figure A-4 on page 147](#).
 - a. If you have your computer connected in data collection mode, you can now type the desired data collection label to replace **L1** from your computer keyboard.
 - b. If your computer is not connected for data collection, use the list of characters in the **Choices** menu to replace **L1**.
8. Position the cursor to line **L2** and select it. Repeat the above step. Repeat again for line **L3**.
9. Press **k5 (Return)**.
10. Position the cursor to **Store labels to file**.
11. Press **k1 (Yes)**.
12. Press **k5 (Return)** to return to the RFTOOLS Select Test Menu.

Figure A-3 **Default Data Collection Label Screen**

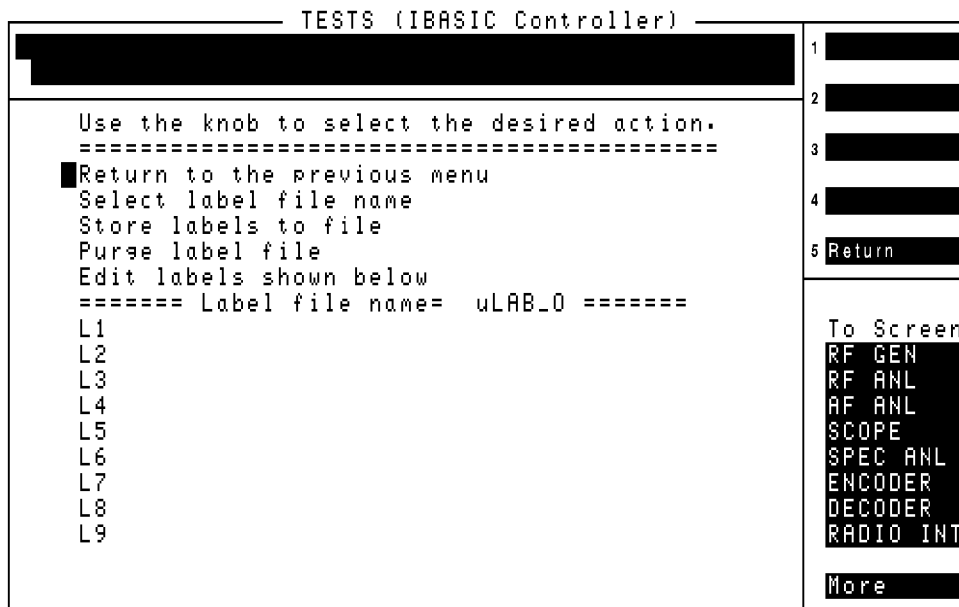
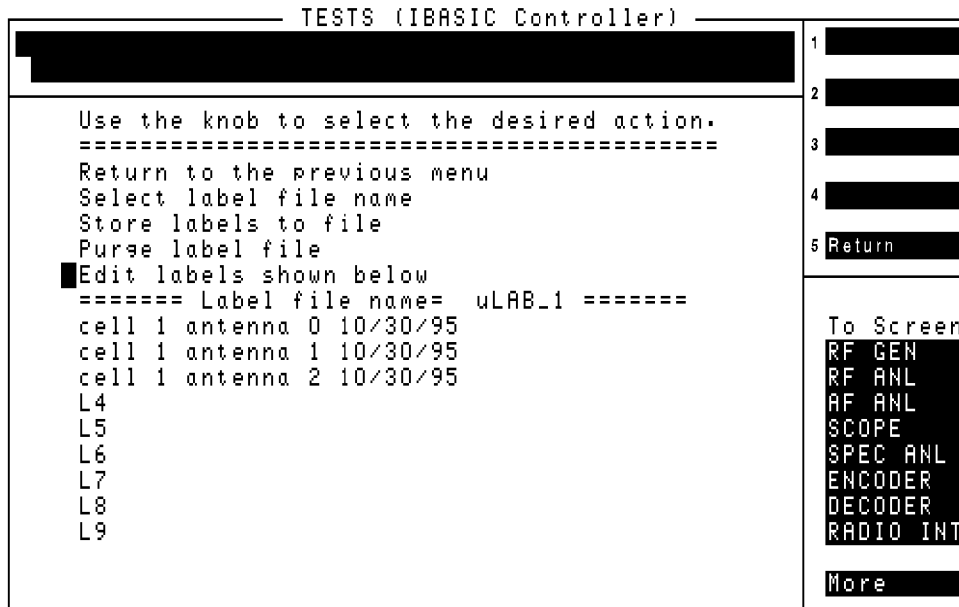

Figure A-4 Labels for Cell 1, Antennas 1, 2, and 3



Running the Swept Return Loss Test

Select the Swept Return Loss test from the **RFTOOLS Select Test Menu**. The screen shown in [Figure A-5 on page 149](#) will appear. The screen gives the following test options:

- Start frequency in MHz
- Stop frequency in MHz
- Max expected loss in dB
- DUPLEX OUT level in dBm

When this test is completed, a plot will be produced showing return loss from the start frequency to the stop frequency. The return loss will be displayed from 0 dB to the value entered in the **Max expected loss in dB** field. If the **Max expected loss in dB** field value is set higher than the measured return loss, the plot will not display any test data. The **DUPLEX OUT level in dBm** field determines the power level at which the test is conducted. When measuring the return loss of antennas, some thought should be given to interference with other receiving antennas. Lower the **DUPLEX OUT** power if you believe this is a problem. If you are testing the transmit antennas of most cellular systems, run the test at 0 dBm.

Figure A-5 Swept Return Loss Setup Screen

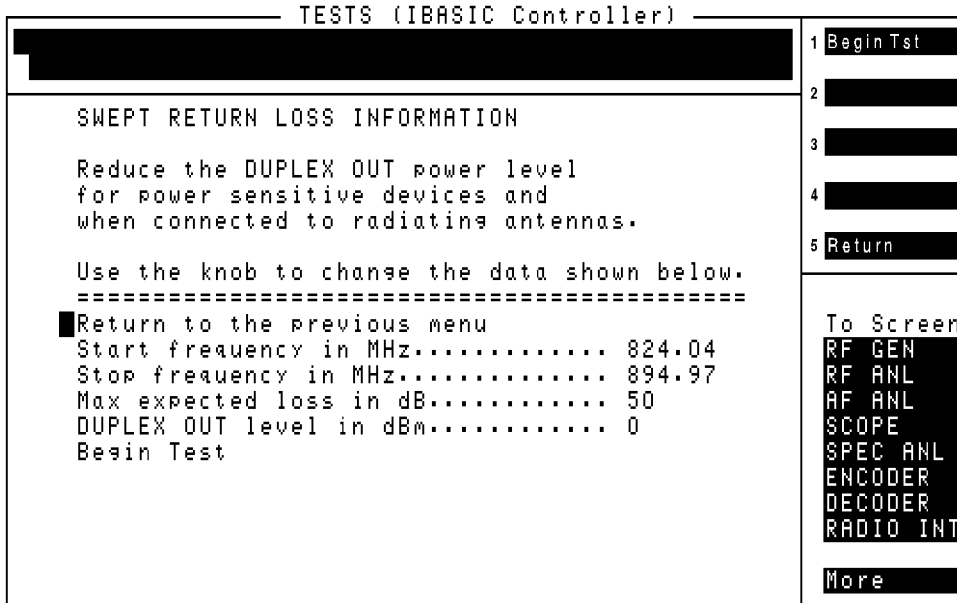

Each of the test options can be changed in two ways.

- You can edit the values directly at the beginning of the test (see [Figure A-5 on page 149](#)).
- You can edit the default values through the parameter table, changing *parameters 1, 2, 8, and 9*.

Press **k1 (Test)**. The screen shown in [Figure A-6 on page 151](#) will be displayed. Make the connections as shown and press **k2 (Continue)** when ready. The test program will calibrate the return loss test. Next, the test set will display the connect diagram shown in [Figure A-7 on page 152](#). The termination in the diagram is the antenna feed cable input. For this example just connect a 6-dB pad to the **Device under test** port. The return loss of an open ended 6-dB attenuator should be 12 dB. This test will determine the accuracy of the attenuator at the test frequencies. Press **k2 (Continue)** when you have the 6-dB attenuator connected.

Figure A-6 Return Loss Calibration Connections

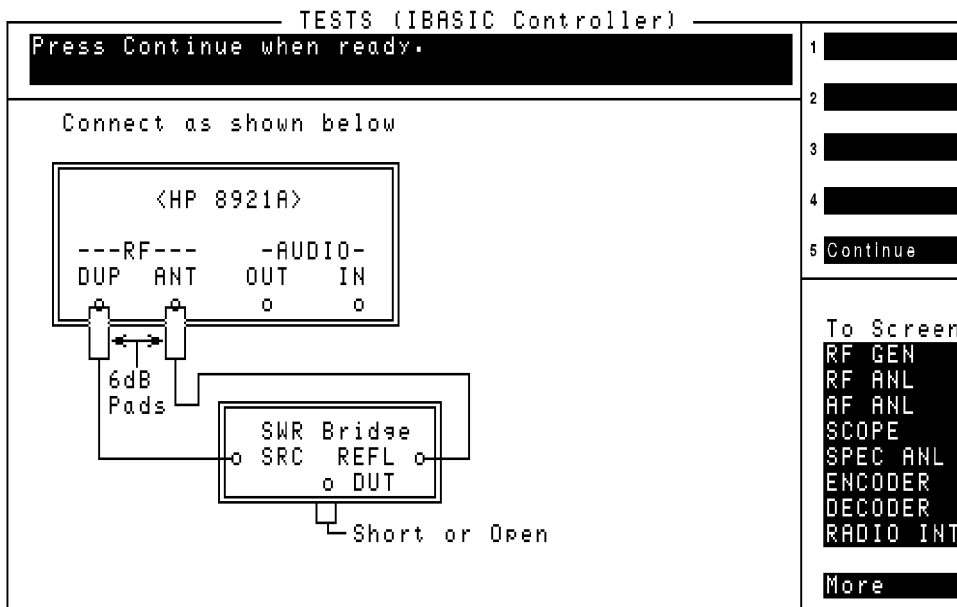
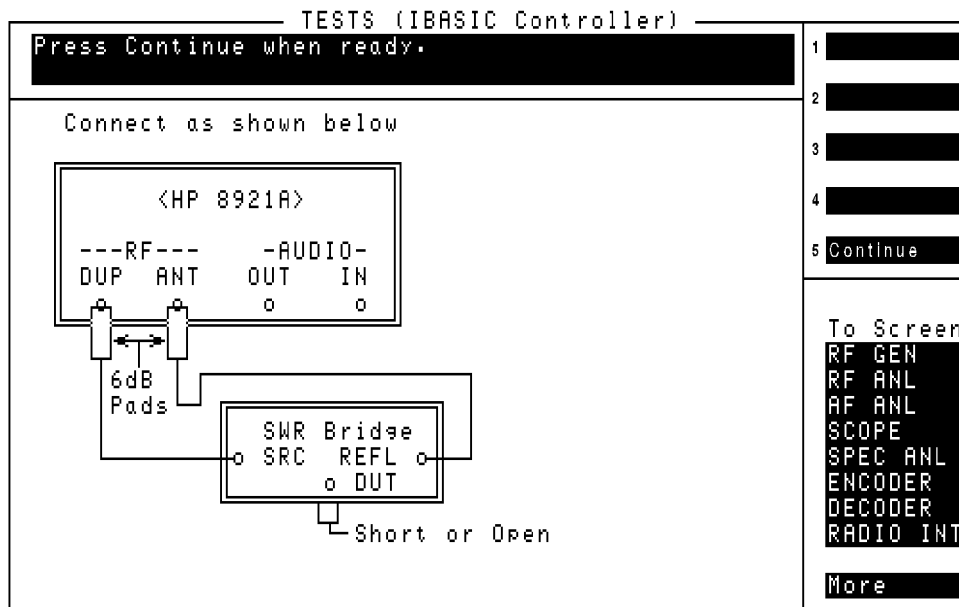

Figure A-7 Return Loss Test Connections



The software will ask **Would you like to label the data from this test.** This message appears because parm_22 Use data collection labels [0=No 1=Yes was set to 1=**Yes** in the previous exercise. Press **k1** (**Yes**). The software will display the screen shown in [Figure A-8 on page 154](#).

This screen presents the following three choices:

- Return to testing without labeling data
- Enter label manually
- Select label from a list.

Select One of the Pre-made Labels

1. Position the cursor to **Select label from a list** and select it. This will display a new screen, containing the labels that were created in the previous exercise.
2. Position the cursor to **Select label from the list below** and select it. This will allow access to the labels below the double line.
3. Position the cursor to the label **cell 1 antenna 0 mm/dd/yy** and select it.
4. The software will prompt **Are you sure you want to use the following label?** and will display the label you selected. If you made the correct selection, press **k1** (**Yes**).

The selected label will be printed with the collected data.

Figure A-8 **Select Data Collection Label Screen**

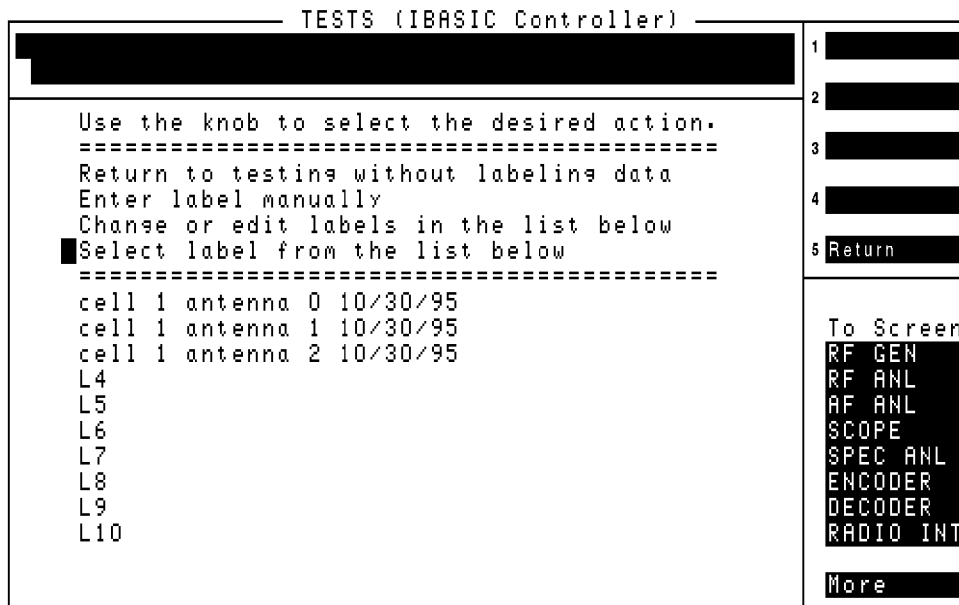

The next screen will be the return loss plot for the 6-dB attenuator. When the plot is displayed, the following softkey options are presented:

- **k2 (Continue)**
- **k4 (Save Plot)**
- **k5 (Scr Dump)**

If you are connected to a printer, press **k5 (Scr Dump)**. You will be instructed to press Shift, Print and then **k2 (Continue)**. After printing, insert a RAM memory card and press **k4 (Save Plot)**. The program will ask for an 8-character file name for the plot. Enter **C1FORL**. After the program responds that the file is stored to the memory card, press **k2 (Continue)**.

The Swept Return Loss test is now complete. The software will present the following choices:

- **k1 (Repeat)**. This allows you to repeat the measurement or measure another device.
- **k5 (Return)**. This will display the final test results, then return you to the RFTOOLS Select Test Menu.

Repeat the Measurement

1. Press **k1 (Repeat)**. Notice that when you repeat, no calibration step needs to be performed. The old calibration will be used.
2. Remove the 6-dB pad and put on a good termination.
3. Press **k2 (Continue)**.
4. The program once again asks for labeling. Label this measurement with **cell 1 antenna 1 mm/dd/yy**.
 - a. Press **k1 (Yes)**.
 - b. Position the cursor to **Select label from a list** and select it. This will display a new screen, containing the labels that were created in the previous exercise.
 - c. Position the cursor to **Select label from the list below** and select it. This will allow access to the labels below the double line.
 - d. Position the cursor to the label **cell 1 antenna 1 mm/dd/yy** and select it.
 - e. The software will prompt **Are you sure you want to use the following label?** and will display the label you selected. If you made the correct selection, press **k1 (Yes)**.
5. When the plot appears, store the plot data to the card with the filename **C1F1RL**.
 - a. Press **k4 (Save Plot)**.
 - b. Enter the filename **C1F1RL**.
6. Press **k2 (Continue)**.
7. Repeat the test again but this time run the test without any connection to the **Device under test** port.
8. Select label **cell 1 antenna 2 10/30/95**.
9. When the plot appears, store the plot data to the card with the filename **C1F2RL**.
10. Press **k2 (Continue)**.
11. Press **k5 (Return)**.

You have now measured and stored the return loss of the three mock antennas. Notice that the data for each of the “antennas” is printed along with the data collection label. When data collection is turned on, the data collection file would look as displayed on the screen.

Running the Replot Data Files Test

While running the Swept Return Loss test in the above exercise, you created three plot files on the RAM card. You may select the Replot Data Files test to look at these plot files.

1. Position the cursor to the **Replot Data Files** test and select it. (You should be on the RFTOOLS Select Test Menu.)
2. Insert the memory card containing the plot files. The software will display the screen shown in [Figure A-9 on page 157](#).

Notice that the program added **_p** to each of the file names. This is to identify them as plot files.

3. Position the cursor to **Select files to replot** and select it. This will allow access to the files below the double line.
4. Select each data file. Once selected, an ***** will appear to the right of each file name.
5. Position the cursor to **Return to menu** and select it.
6. Position the cursor to **Replot files selected below** and select it. Each plot will now be recalled and replotted.
7. Press **k2 (Continue)** to move from one plot to the next. Notice that while viewing each file, you can print or re-save the file to the card.
8. After viewing each plot file press **k2 (Continue)**, then **k5 (Return)**.

Figure A-9 Replot Select Menu

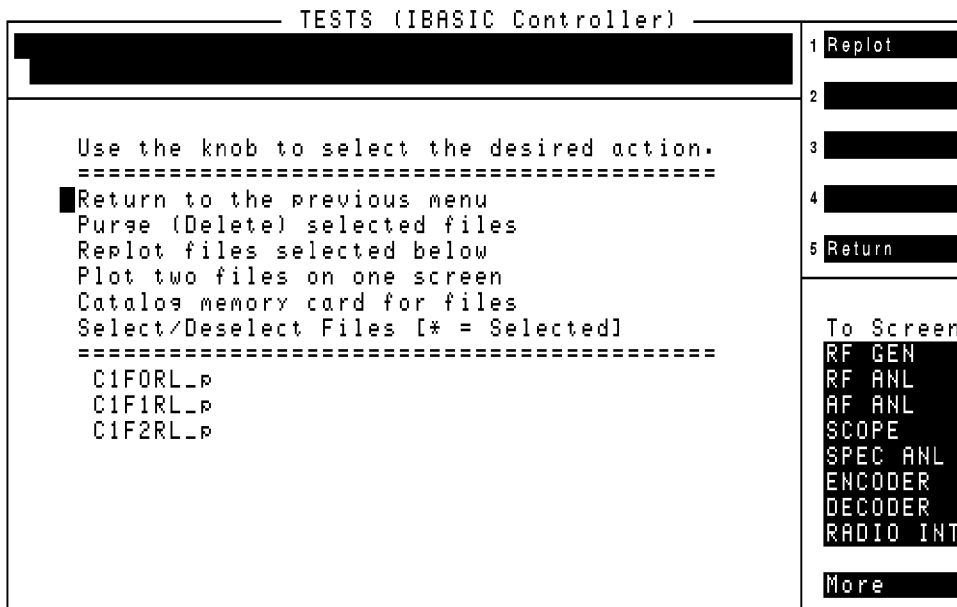

Plotting Two Files

The Replot Data Files test also allows you to compare the data from two plots.

1. Position the cursor to the Replot Data Files test and select it. (You should be on the RFTOOLS Select Test Menu.)
2. Insert the memory card containing the plot files. The software will display the screen shown in [Figure A-9 on page 157](#).
3. Position the cursor to **Plot two files on one screen** and select it. The software will display the screen shown in [Figure A-10 on page 159](#). You will have the following options:
 - a. **Return to previous menu:** returns to the RFTOOLS Select Test Menu.
 - b. **Legend location:** you may select top or bottom for the placement of the plot legend.
 - c. **Primary plot file name:** sets the borders and titles for the plot.
 - d. **Secondary plot file name:** data from this file will be plotted within the primary plot borders.
 - e. **Plot:** executes the plotting command.
4. Select a primary and secondary plot file.
5. Press **k1 (Plot)**. See [Figure A-11 on page 160](#).
6. When you are ready, press **k2 (Continue)**.
7. Try different combinations of the three plots that you saved in the earlier exercise.
8. When you are finished, press **k5 (Return)**.

Figure A-10 Plot Two Files Select Menu

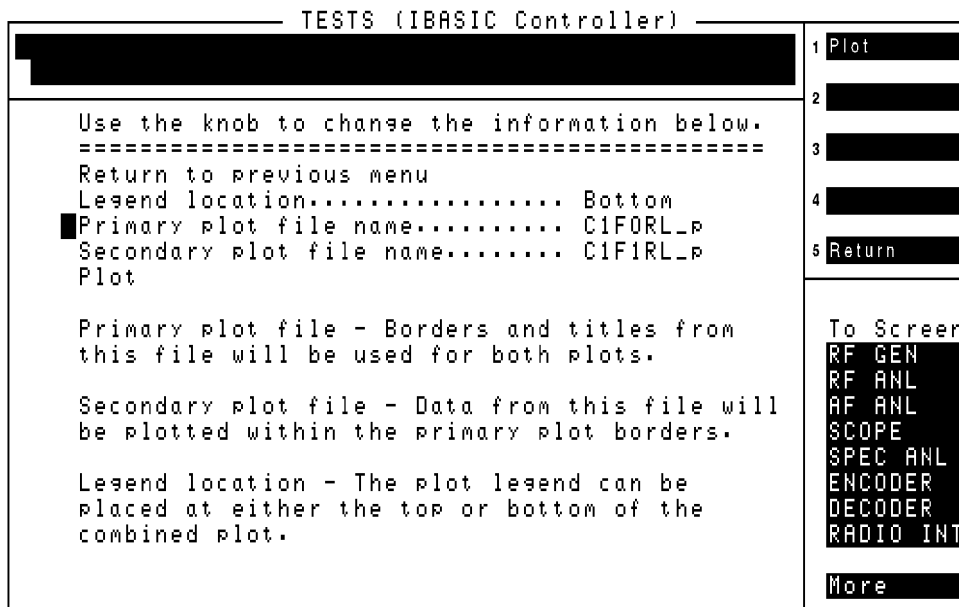
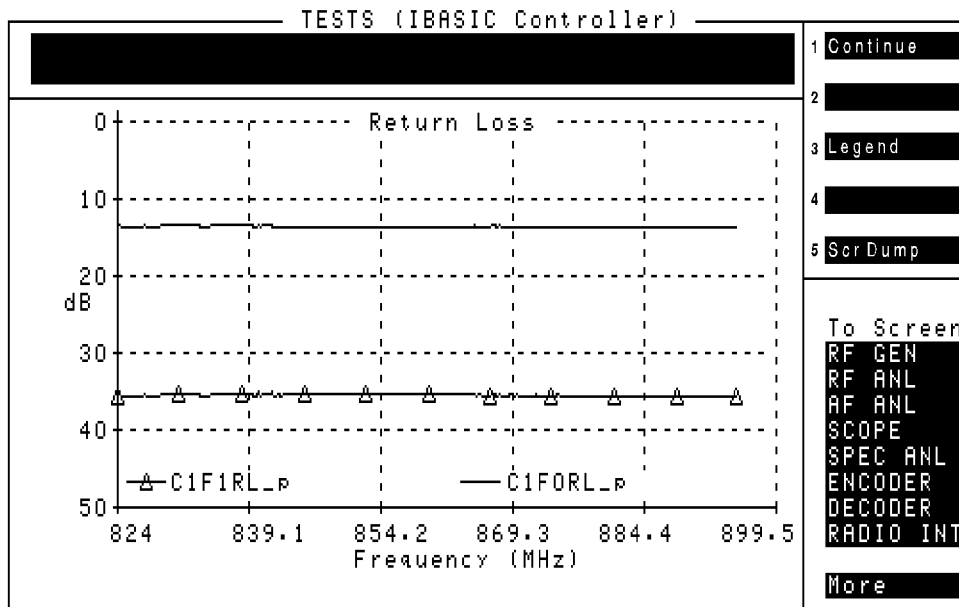

Figure A-11 Example from "Plot Two Files"



Overview of the Cable Fault Test

The cable fault test calculates the return loss of impedance mismatches as a function of distance down a cable length. The primary use of the program is to determine if antenna feed cables, cable splices, or joints are broken or damaged.

Select the Cable Fault test from the RFTOOLS Select Test Menu. The software will display the Cable Fault Test Information screen shown in [Figure A-12](#). The screen allows the following values to be edited:

- Cable length
- Cable length units (toggles between feet and meters)
- Cable class
 - HELIAX
 - RG
 - Custom
- Cable type (If Custom was selected above, this field does not appear. **Cable velocity propagation constant** and **Cable atten. dB/100 ft at 500 MHz** will appear instead).

Figure A-12 Cable Fault Test Data Information Screen

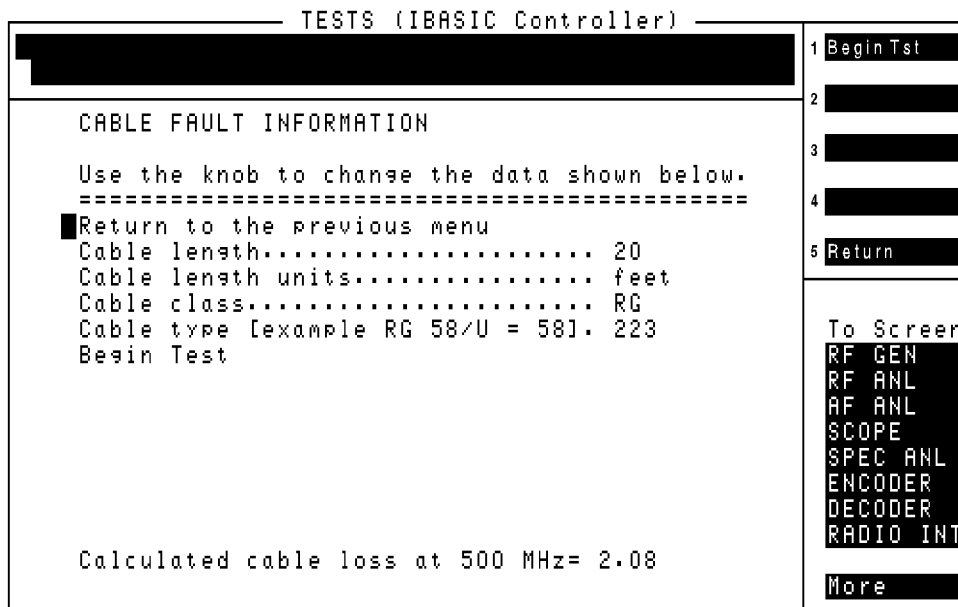

Selecting Cable Class: RG

The factory default is set to test 20 feet of RG 223 cable. Note that the calculated loss for 20 feet of RG 223 at 500 MHz is displayed at the bottom of the screen. This calculated cable loss feature is convenient when estimating the loss of cables at other frequencies. If your frequency is higher, say 881.5 MHz for cellular, the loss will be higher, but this number will give you an optimistic estimate.

Selecting Cable Class: HELIAX

1. Position the cursor to the **Cable class** field, and select **HELIAX**.
2. Position the cursor to the **Cable type** field and select it. The screen will display the choices shown in [Figure A-13](#). Your cell site will likely use some form of heliax cable for the antenna feed lines.
3. Select choice 5, **1-5/8" Foam**.
4. The software will return to the Cable fault test information screen shown in [Figure A-14](#) on page 163.

Figure A-13 HeliAx Cable Options (Cable Fault Test)

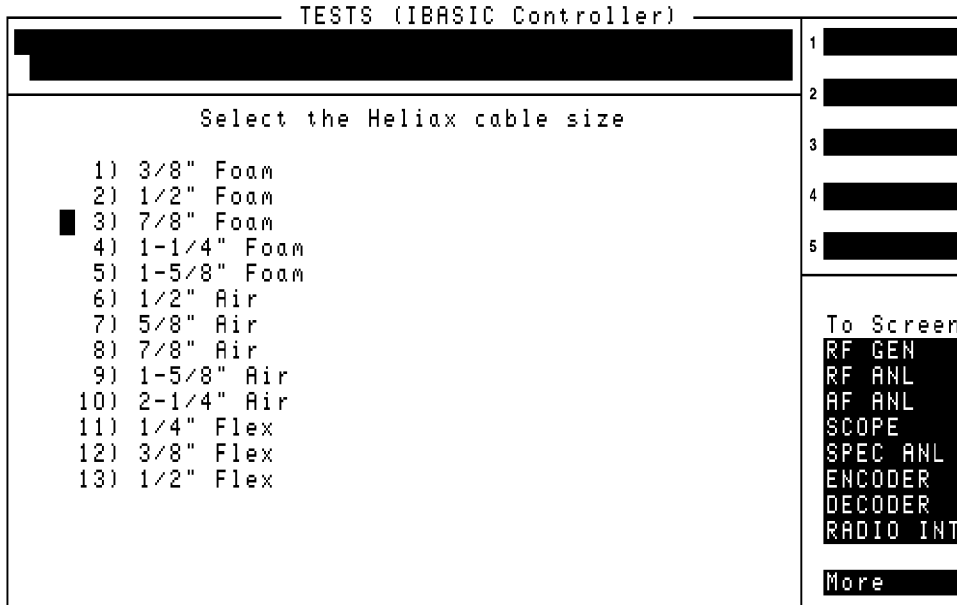
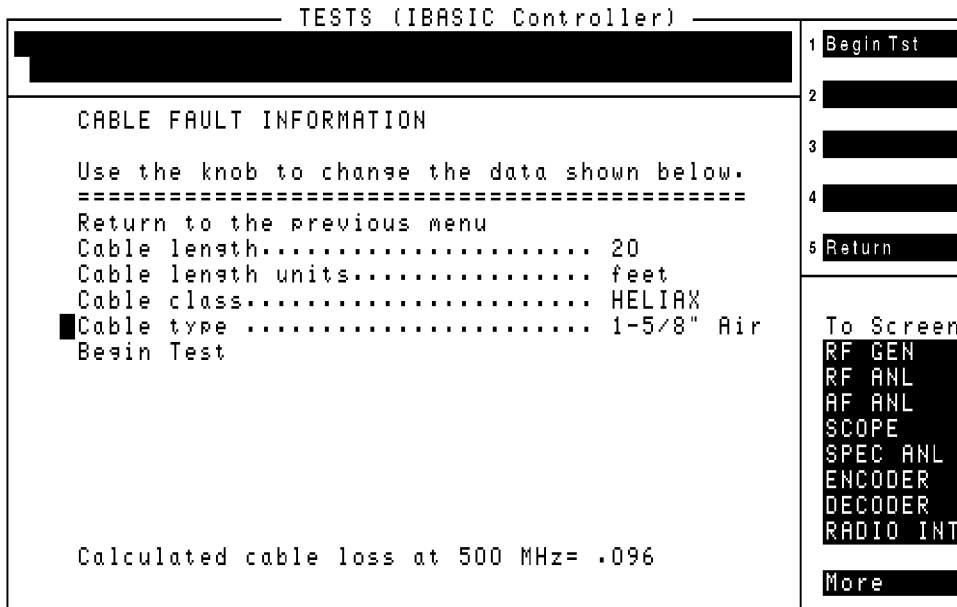

Figure A-14 Helix Cable Data Information Screen (Cable Fault Test)



Selecting Cable Class: Custom

1. Position the cursor to the **Cable class** field, and select **Custom**.
2. The list of parameters will change, adding the fields **Cable velocity propagation const.** and **Cable atten. dB/100 ft at 500 MHz**. See [Figure A-15](#). This option is provided in case you use a cable type other than RG or HELIAX. Enter the appropriate values for these parameters.

Figure A-15 Cable Fault “Custom” Data Information Screen

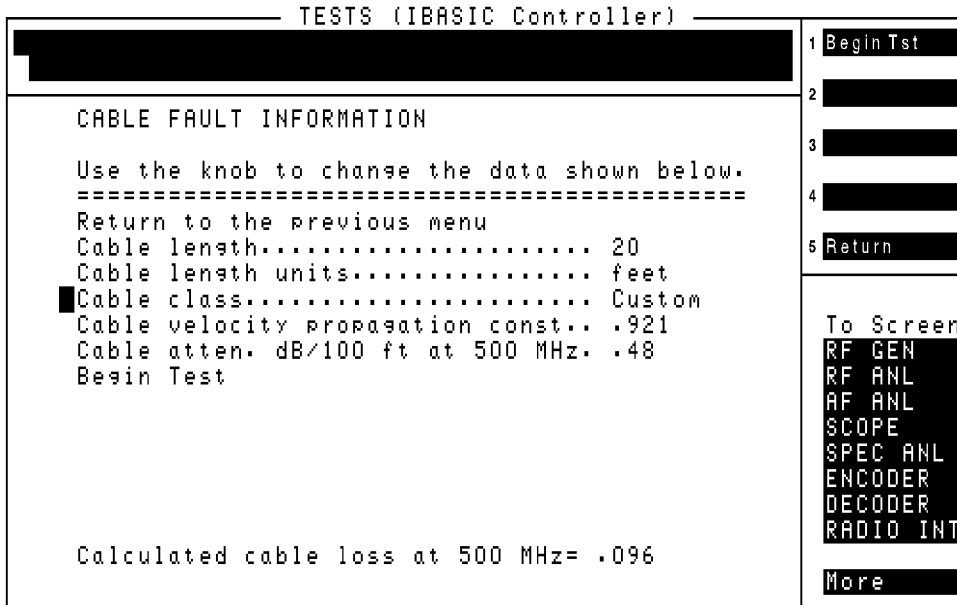

Running the Cable Fault Test

1. Set up the **Cable fault test information** screen to test for cable faults along a 20 foot length of RG 223 cable.
 - a. Enter **20** in the **Cable length** field.
 - b. Select **feet** in the **Cable length units** field.
 - c. Select **RG** in the **Cable class** field.
 - d. Enter **223** in the **Cable type** field.
2. Press **k1 (Begin Tst)**.
3. Make the connections shown on the test set's screen. See [Figure A-16 on page 166](#).
 - a. Make sure you are using the power divider and not the reflection bridge.
 - b. Make sure the test port is terminated in 50 ohms.
4. Press **k2 (Continue)**.

The test set will take a moment to make calibration measurements. When the calibration measurements are complete the software will display the screen shown in [Figure A-17 on page 167](#).

Figure A-16 Calibration Connections (Cable Fault Test)

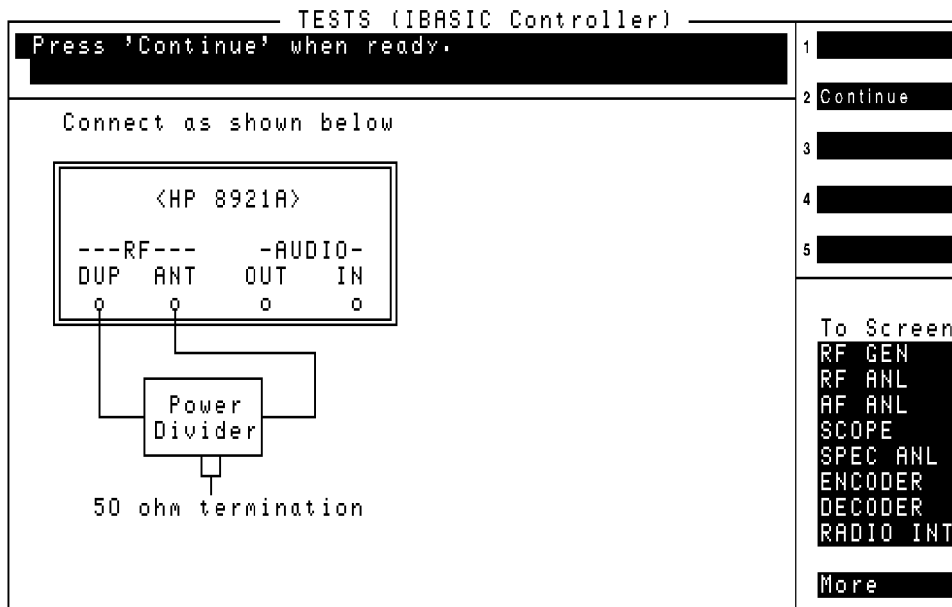
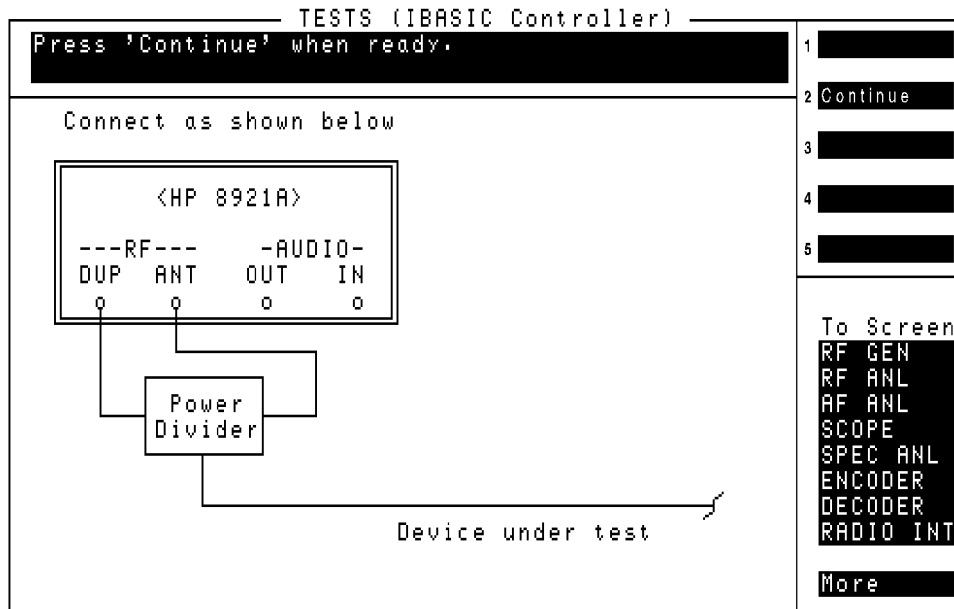

Figure A-17 Cable Fault Test Connections



**Simulate an
Antenna
Connection
(Infinite Cable)**

1. Connect a 10-foot section of RG 223 cable terminated in a 50 ohms.
2. Press **k2 (Continue)**.
3. The software will ask if you want to label the data from this test. Press **k1 (Yes)**.
4. The data collection labels you created for cell site 1 should be displayed. Select **cell 1 antenna 0 mm/dd/yy**, then **k5 (Return)**.

The test will now plot the test results, as shown in [Figure A-18 on page 169](#). This plot shows no faults in the cable. Regardless of how long the cable is, the length of the cable is seen as infinite here. The length of the line is important in the next section because it controls the width of the distance portion of the graph. For example, if the cable length was entered as 10 feet, the cable fault on the screen may not appear, or at least would not be as easily interpreted. Since there were no impedance mismatches on a line terminated in 50 ohms, no faults are displayed.

When the plot is displayed, the following softkey options are presented:

- **k2 (Continue)**
- **k4 (Save Plot)**
- **k5 (Scr Dump)**

1. Press **k4 (Save Plot)**.
2. Store this plot to the memory card under file name **C1F1CF**. Press **k2 (Continue)**.

Figure A-18 Cable Fault Test Result for 50 Ω Terminated Cable

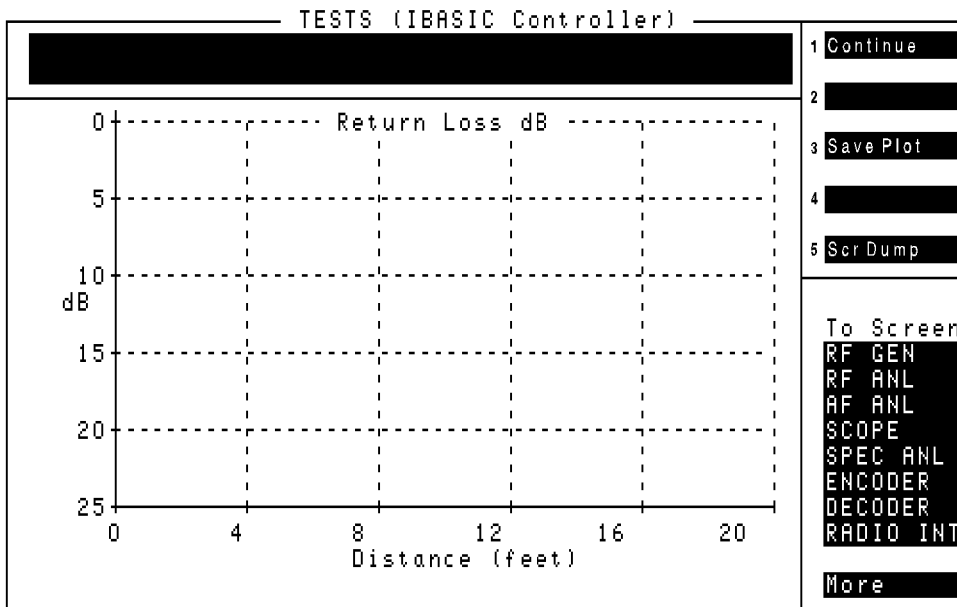

The cable fault test is now complete. The software will present the following choices:

- **k1 (Repeat)**. This allows you to repeat the measurement or measure another device.
- **k3 (Disp data)**. This allows you to display numerical data from the test. You may again press **k3 (Plot data)** to return to the plot.
- **k5 (Return)**. This will display the final test results, then return you to the **RFTOOLS Select Test Menu**.

Press **k3 (Disp data)** to see the screen shown in [Figure A-19](#). This data shows the return loss at the sixth highest return loss point along the line. For the termination in [Figure A-19](#), the highest return loss point was at the end of the cable. All of these return loss values are excellent and would require no action.

NOTE

Note that the loss readings that appear in [Figure A-19](#) are all below the 25 dB threshold of [Figure A-18 on page 169](#). Therefore, they do not appear in [Figure A-19](#).

Figure A-19 Cable Fault Test Data for 50 Ω Terminated Cable

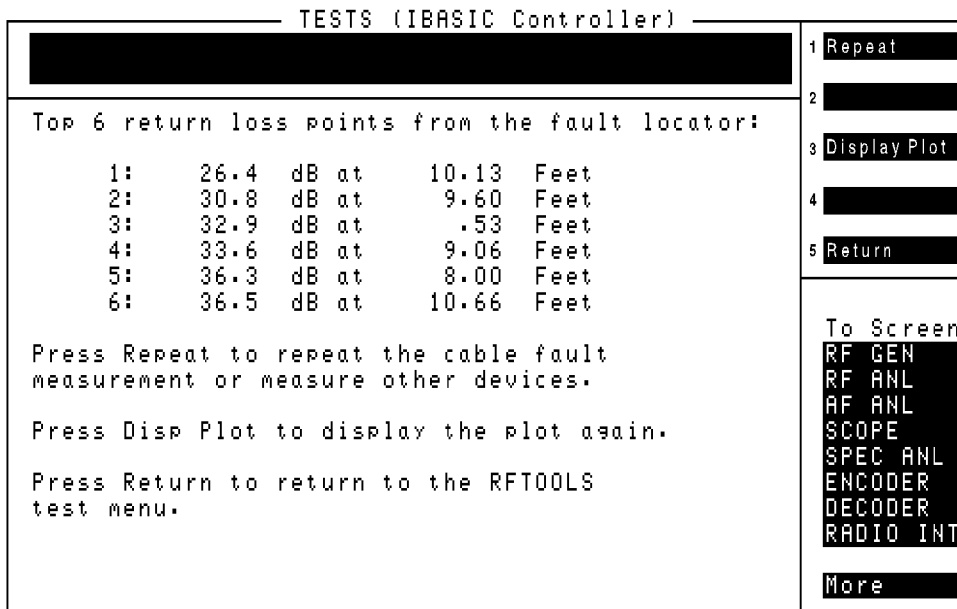

Repeat the Measurement for Antenna 1

In this example, we will remove the 50 Ω termination and replace it with a lower attenuator. This new attenuator will provide an impedance mismatch and simulate a cable fault at approximately 10 feet.

1. Press **k1 (Repeat)**. The connection diagram will be displayed again.
2. Remove the termination from the end of the 10 foot cable and replace it with a 6-dB attenuator. Leave the output end of the attenuator open.
3. Press **k2 (Continue)**.
4. Wait for the spectrum analyzer to complete its measurement and FFT calculation.
5. Label the data with **Cell 1 Antenna 1 mm/dd/yy**.

The plot shown in [Figure A-20](#) will be displayed. Note the 12-dB fault at 10 feet. Store the plot to the memory card with the filename **C1F1CF**. When the plot is stored press **k3 (Disp data)**. You will see data similar to that shown in [Figure A-20](#). The largest fault in [Figure A-20](#) was found at 10.13 feet and 12.1 dB. The return loss of an open circuited 6-dB attenuator should be 12 dB.

Figure A-20 Cable Fault From a 6-dB Attenuator at 10 Feet

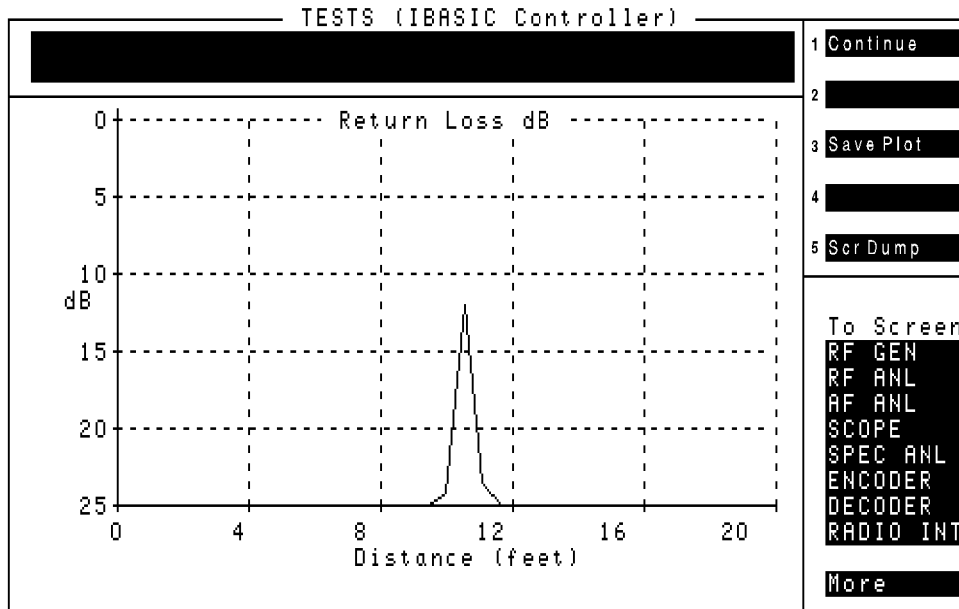

Repeat the Measurement for Antenna 2

1. Press **k1 (Repeat)**. The connection diagram will be displayed again.
2. Remove the 6-dB attenuator from the end of the 10-foot cable. Leave the cable open.
3. Press **k2 (Continue)**.
4. Wait for the spectrum analyzer and the FFT.
5. Label the data with **cell 1 antenna 2 mm/dd/yy**.
6. The plot shown in **Figure A-21** will be displayed. The largest mismatch reading is most likely the location of a cable fault. Other numeric data points, particularly if they are farther down the line from a point of high relative mismatch, can be ignored.
7. Store this plot on the memory card with the file name **C1F2CF**.
8. Press **k2 (Continue)**.
9. Press **k3 (Disp data)**. The cable fault data will be displayed. All 6 top return loss points should be around the 10 foot length.
10. Press **k5 (Return)**.

Figure A-21 Cable Fault From an Open Circuit at 10 ft.

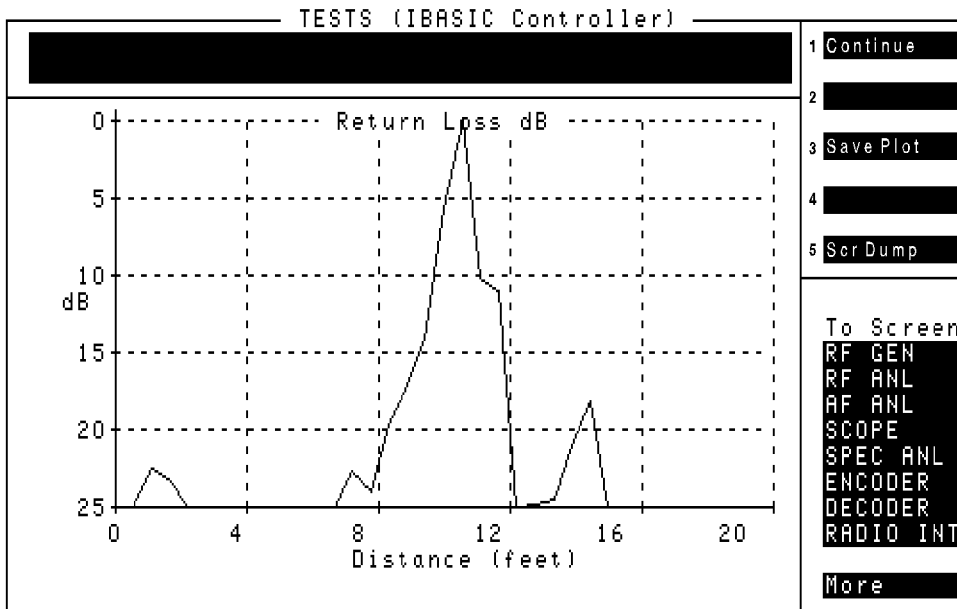

Plot the Two New Files

1. Position the cursor to the Replot Data Files test and select it. (You should be on the RFTOOLS Select Test Menu.)
2. Insert the memory card containing the plot files.
3. Position the cursor to Plot two files on one screen and select it.
4. Position the cursor to Primary plot file name and select C1F1CF_p.
5. Position the cursor to Secondary plot file name and select C1F2CF_p.
6. Press k1 (Plot). A plot similar to Figure A-22 will be displayed.

Figure A-22 Comparison of 6 dB and Open Circuit Faults at 10 ft.

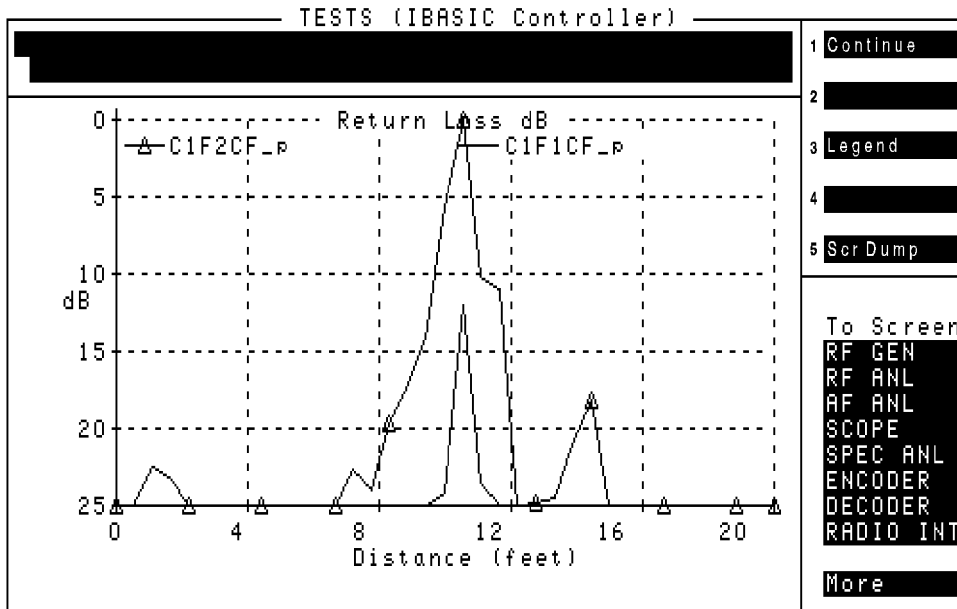

Try plotting one of the cable fault tests with one of the return loss tests. It will plot, but it may look very strange. Plot two files on one screen will plot any two plot files regardless of the plot type or whether the output makes any sense.

C

CANCEL A key used to pause (stop) the IBASIC program running in the test set.

card Refers to the memory card containing the procedures for testing the unit-under-test.

Choices Refers to a field in the lower right of the screen that displays several possible functions for selection

Continue Proceed with the IBASIC software program if it has been stopped (paused).

cursor Refers to the brightened region of the screen used to indicate the field/function currently being accessed.

D

Del Step A function to delete a step in the procedure.

Disp Loc A menu function which presents an assembly diagram that displays location of the adjustable component.

E-F

ESD ElectroStatic Discharge - A transfer of electric charge from one place to another. Devices can be damaged by the energy transferred during the discharge.

field An area on the CRT with an inverse video display (**example**) where entries can be made.

format See “initialize”

function Refers to a particular field, feature, or operation of the test set

H-I

Help A feature providing specific information about how to use the current screen in the TESTS environment. This feature is accessed by pressing k4 (**Help**) from any TEST screen. Note: only available in the HP 8920B and HP 8920A,D firmware above revision A.14.00.

HELP A feature providing additional test set information accessed by pressing SHIFT, then TX (HELP) keys. Help topics are listed in alphabetical order.

highlight Refers to the brightened region (cursor) of the screen used to indicate the field/function currently being accessed.

IBASIC Instrument BASIC is the computer language (code or software) used by the test set’s built-in controller. The IBASIC software is downloaded from the OTP CARD into the test set’s RAM. This software is then used to control the test set during autotesting the unit-under-test.

initialize A card or disk must be initialized (formatted) prior to storing data. This may be done by pressing **k3 (Init Card)** on the TESTS (Save/Delete Procedure) screen, or by using the formatting function of the SAVRCL procedure (see [page 92](#)). The default for Epson Cards (HP 11807A) is LIF format. See “[Memory Cards](#)” on [page -110](#) for information on changing these default settings.

K - L

key (USER keys) Keys refer to any of the push buttons on the front panel of the test set. The USER keys are a specific grouping of keys labeled k1 to k5 which perform the associated numbered function in the action field located in the upper right of the screen. The USER keys are user programmable.

knob The large tuning dial for cursor control located in the center of the test set front panel. This knob is rotated to position the cursor on the screen and then pressed to select the particular field or function.

library A collection of all of the parameters, pass/fail limits and tests associated with a particular software program. A software card may come with one or more libraries, and consequently one or more software programs. The test software and the test set's firmware use the library, test software program code file, and a procedure to run a customized application program. A library is stored as a file on a memory card or other mass storage with its associated procedure files

Location Where to retrieve or save a particular testing procedure, for example, to a disk, card, RAM, or PC

M

measurement A series of calculations on data measured by the test set. These calculations provide a value to be compared against pass/fail limit values that verify the performance of the unit-under-test.

Main Menu The screen accessed by pressing the TESTS key, or K5 Main Menu. It is used to customize and execute (run) automated testing.

Also referred to as the "TESTS" screen.

menu The test set's screen displays various tasks to be selected with the cursor control knob or the USER keys; this display is the menu.

message The upper portion of the test set's screen is reserved for messages and prompts. Messages give an indication of the status of the test set, for example, **System initialization.**

O - P

OTP One Time Programmable (OTP) refers to a CARD on which code or date may only be stored once; similar to ROM. The HP 11807A/E software is shipped on an OTP memory card.

parameters Entries you make for calibration data, phone characteristics, or test customization. They give you flexibility in the way you use the software. Default values for parameters are present in the software.

pass/fail limits Pass/fail limits are the names of criteria verifying the performance of the unit-under-test. Usually, the associated measurement value must fall within the HI/LO limits of pass/fail values to verify performance of the unit-under-test. Default values in the test software have been derived from standard methods of measurement or from the unit-under-test requirements. Note: pass/fail limits are not used by the HP 11807A,E Option K13 software.

pause Using the CANCEL key pauses the running of IBASIC software in the test set and allows access to the keyboard functions. CONTINUE allows the software to proceed.

peak +/- max A detector in the test set that measures and computes the maximum of the absolute value of the positive and negative excursions of the measurement. For example, when an FM waveform with a +10 kHz and -9 kHz deviation is applied, 10 kHz will be displayed

PRESET Sets the test set to its initial power-up state.

procedure A shortened label for test procedure. A procedure is a collection of channels (FIELD_S and SCANNER libraries only), parameters, and testing order, saved in a file, that customizes the test software to a specific application. Procedures are made by editing existing channels, parameters, and testing order, and saving the resulting files to a memory card, disk or internal test set RAM.

prompts The upper portion of the test set (inverse video field) is reserved for prompts and messages. The prompt directs the user to take some action. Messages give an indication of the status of the test set.

R

RAM Random Access Memory - The memory in the test set that is used to store program code and data. The test set's RAM is battery-backed-up, retaining data and program codes when the power is turned off.

ROM Read Only Memory

Run Test Directs the test set to load the program from the current procedure and begin testing (may take up to two minutes).

S - V

save Save and store are used synonymously and refer to putting data or software on some memory device, such as, card or RAM.

screen Refers to the video display of the test set.

select To choose a particular field or function. Rotate the CURSOR CONTROL knob and position the highlighted cursor on the chosen field or function, then press the knob. An alternative method is to press the numbered USER key having the same number as displayed alongside the desired function.

softkey The name of the set of keys next to the CRT display that can be assigned to certain special actions or fields. The keys are also called USER keys.

SRAM Static Random Access Memory - A data storage device. SRAM memory cards can be used with the test set to save programs and test results

Step# Orders the sequence of tests, e.g. Step #1 may be Test_5, and Step #2 may be Test_26 and so on.

store Store and save are used synonymously and refer to putting data or software on some memory device, such as card, RAM.

tests Tests are a collection of measurements (or a series of other tests) which verify a particular specification value or operation of the UUT. A sequence of tests are contained in a test procedure.

TESTS screen The screen accessed by pressing the TESTS key. It is used to customize and execute (run) all automated testing. Also referred to as the "Main Menu"

USER keys A group of keys located immediately to the right of the test set's screen that allow the user to more rapidly select certain functions without rotating and pressing the knob. These key assignments are displayed in the upper right portion of the test set's screen. The number on the left of the function corresponds to the number on the user key k1 to k5.

values The scalar quantities or numbers inserted in the inverse video fields of the pass/fail limits or parameters. Units of measure (dB, inches, volts, watts, etc.) are contained in the pass/fail limits and test parameters.

Numerics

1-800 help line, [11](#)

A

additional services available, [11](#)

AdvanceLink, [100](#)

amps channel return loss
test description, [45](#)

ANT IN port

power input warning, [39](#)

antenna return loss
how to estimate, [43](#)

ASCII file type, [97](#)

Autostart Test Procedure on
Power-Up, [136](#)

B

BDAT file type, [97](#)

C

cable
 testing losses, 40
cable fault
 equipment needed, 144
 test description, 47
cable fault performance, 47
cable fault test
 calibration connections, 165
 infinite cable, 168
 overview, 161
 repeating the measurement, 171
 selecting cable class, 161
cable length
 entering, 49
cable type
 selecting, 47
Calculate Intermods, 77
CANCEL, 117
card
 how to insert, 18
CAT IBASIC command, 96
catalog memory card
 test description, 58
Catalog the Memory Card, 87
Changing the Order of Tests, 23
channel information
 discrete scan, 80
 securing, 129
 swept scan, 82
Choices, 95
choose, 95
Clr Scr, 137
configuration
 for data collection, 97
 for terminal or PC operation, 103
configuring an IBM-compatible PC with HP AdvanceLink, 100
connecting a printer, 119
connections
 parallel printer, 120
 RJ-11 connector, 119
 serial printer, 119
Continue, 137
Continue USER key, 117
continuing a paused program, 117
conventions used, 95
COPY IBASIC command, 96
copying files, 96
create/edit data collection labels
 test description, 59
customizing testing, 20

D

data collection
 description, 97
 entering the configuration for, 97
 example configuration, 98
 memory card part numbers, 111
 retrieving data, 114
 saving to a memory card, 97
 to a PC, 100
 to a PC, setting up, 103
 transfer stored data, 56
data collection labels
 editing, 59
Del Proc, 137
Delet Stp, 137
deleting a procedure, 128
discrete channels
 measuring the return loss, 45
discrete scan frequency
 information, 80
Done, 137
DOS file type, 97
DUPLEX OUT
 setting level, 148
DUPLEX OUT power level
 note about setting, 42

E

Edit Configuration
 data collection to a PC, 103
Edit Spec, 116
effective radiated power, 53
enter, 95
ENTER key, 95
equipment needed, 9
 swept return loss and cable fault, 144
equipment supplied, 9
ERP calculator
 test description, 53
escape sequences, 122

F

- Factory Hot Line, [11](#)
- field
 - selecting a, [95](#)
- field strength measurement
 - procedure description, [70](#)
- FIELD_S
 - procedure description, [70](#)
- file types, ASCII, BDAT, DOS, and HP-UX, [97](#)
- files
 - copying, [96](#)
- Formatting a memory card, [92](#)
- frequency information
 - discrete scan, [80](#)
 - swept scan, [82](#)
- front-panel control characters, [107](#)

H

- hardware
 - must be installed in test set, [10](#)
- heliac, [48](#)
- Help, [137](#)
- HP 11807A,E Software
 - description, [17](#)
- HP-IB control annunciators, [109](#)
- HP-IB printer, [120](#)
- HP-IB printer connections, [119](#)
- HP-UX file type, [97](#)

I

- IBASIC
 - copying files, [96](#)
 - TESTS screen, [20](#)
- IBASIC commands
 - entering from a terminal, [96](#)
- If Unit-Under-Test Fails, [136](#)
- If Unit-Under-Test-Fails, [32](#)
- If UUT Fails, [136](#)
- infinite cable
 - simulating, [168](#)
- Init Card, [137](#)
- initializing an SRAM memory card, [113](#)
- initializing RAM disks, [132](#)
- insertion loss
 - test description, [40](#)
- Insrt Stp, [137](#)
- interference
 - caused by test signal, [42](#), [47](#)
- Intermods
 - calculating, [77](#)
- intermodulation products
 - parameters, [77](#)
- items supplied in the software package, [9](#)

L

labels
 building a list, [145](#)
 data collection, [142](#)
 selecting pre-made, [153](#)
legend location
 field description, [158](#)
library
 loading code from, [17](#)
 saving, [28](#), [125](#)
 selecting, [23](#)
loading a procedure, [128](#)
loading software, [17](#)
Location, [18](#)
loss
 AMPS Channel return, [45](#)
 insertion, [40](#)
 swept return, [42](#)

M

Main Menu, [137](#)
Measure Test Plan, [72](#)
measurement plan, [70](#)
measurements, [38](#), [72](#)
memory card
 catalog, [58](#)
memory card, formatting, [92](#)
memory cards
 are used for, [110](#)
 determining whether it is OTP,
 flash, or SRAM, [110](#)
 how they're powered, [110](#)
 initializing, [113](#)
 inserting, [110](#)
 OTP, [110](#)
 removing, [110](#)
 retrieving data from, [114](#)
 saving data to, [97](#)
 software, [17](#)
 SRAM, [110](#)
 SRAM battery part number, [111](#)
 Static Random Access Memory
 (SRAM), [111](#)
 storage space needed, [112](#)
 write protect switch, [111](#)

O

option 102
 spectrum analyzer and tracking
 generator, [10](#)
options required, [9](#)
order of tests
 printing, [118](#)
 saving, [126](#)
OTP
 memory cards, [110](#)
Output Destination, [135](#)
Output Heading, [32](#), [136](#)
Output Results, [135](#)
Output Results For, [32](#), [135](#)
Output Results To, [32](#), [135](#)

P

parallel printer connections, 120
 parameter
 RFTOOLS overview, 142
 parameters
 editing values, 26, 115
 general description, 26, 115
 intermodulation products, 77
 printing, 118
 saving, 28, 115, 126
 securing, 129
 part numbers
 equipment needed, 9
 memory card battery, 111
 software memory cards, 9
 SRAM Memory Cards, 111
 User's Guide, 9
 pass number, 129
 pass/fail limits
 not used, 116
 securing, 129
 pausing a test, 16, 117
 PC
 collecting data to, 100
 plotting two files, 158, 173
 PRESET, 18
 print options
 pitch, margins, paper size,
 typeface, 122
 print stored measured data, 73
 printer
 HP-IB, 120
 output heading, 136
 serial, 120
 printers supported, 118
 printing, 118
 test results, 135
 test results using firmware
 above revision A.14.00, 121
 TESTS Screens, 124
 Procedure, 18
 procedure, 72
 deleting, 128
 general description, 28, 125
 loading into test set memory,
 128
 names, 125
 saving, 28, 126
 securing, 129
 un-securing, 130
 what is saved, 125
 program
 stored in test set memory, 110
 Purge files from memory card, 88

R

RAM
 disk, 131
 initializing, 131
 REC=
 default entry, 98
 entering record number, 98
 REC= to set record size, 98
 repeating a measurement, 155
 replot data files test
 running, 156
 replot stored plot data
 test description, 54
 Restoring save/recall registers to
 test set, 91
 return loss
 calibration connections, 150
 RFTOOLS
 parameter overview, 142
 selecting procedure file, 141
 test overview, 144
 RG, 48
 Run, 137
 Run Mode, 136
 Run Test, 137
 running tests, 13
 overview, 15

S

SA Self Calibration ON/OFF
 test description, 57
 Save Proc, 137
 Save/Recall Registers
 catalog, 87
 purging, 88
 Restoring, 91
 save to card, 89
 saving
 procedure, 28
 test procedure, 28
 test results, 97
 saving a procedure, 126
 saving plot, 154
 Saving save/recall registers to
 card, 89
 SECURE IT ROM program, 129
 securing a procedure, 129
 select, 95
 selecting cable type, 47
 self-calibration
 spectrum analyzer, 140
 sequence
 changing, 23
 general description, 23
 saving, 28
 serial printer, 120
 serial printer connections, 119
 softkeys, 137
 software
 how to load, 18
 loading, 17
 stopping the, 117
 software package
 items supplied in, 9
 special display conventions used,
 95
 specifications
 not used, 116
 spectrum analyzer calibration
 test description, 57
 SRAM
 memory cards, 110, 111
 starting up, 18
 stop on failure, 32
 stopping a test, 16, 117
 stopping the program
 using Test Execution
 Conditions, 32, 135
 Swept Gain, 38
 swept insertion loss
 test description, 40
 swept return loss
 equipment needed, 144
 test description, 42
 swept return loss test

calibration connections, [150](#)
repeating a measurement, [155](#)
running, [148](#)
swept scan frequency
information, [82](#)

T

terminal emulator
configuration, [103](#)
DataStorm Technologies, Inc.
ProComm, [100](#)
HP AdvanceLink, [100](#)
test descriptions, [38](#)
Test Execution Conditions, [32](#),
[135](#)
test overview
RFTOOLS, [144](#)
test parameters
editing values, [115](#)
general description, [115](#)
test procedure, [28](#)
saving, [126](#)
Test Procedure Run Mode, [32](#), [136](#)
test results
printing using firmware above
revision A.14.00, [121](#)
retrieving from a memory card,
[114](#)
saving, [97](#)
where sent, [135](#)
test time, [117](#)
testing order
securing, [129](#)
testresults
output failures, [135](#)
tests
entering a sequence of, [23](#)
environment and conditions, [26](#)
pausing, [16](#)
pausing or stopping, [117](#)
required order, [72](#)
running, [13](#), [16](#)
stopping, [16](#)
transfer stored data
test description, [56](#)

U

user key, [95](#)
USER keys, [137](#)

V

VSWR

how to calculate, [42](#)

W

WARNING

ANT IN port power input, [39](#)